

**ARCS<sup>®</sup> WIDE SYSTEM**  
**ARCS<sup>®</sup> FOCUS SYSTEM**  
**RIGGING MANUAL**  
VERSION 2.0

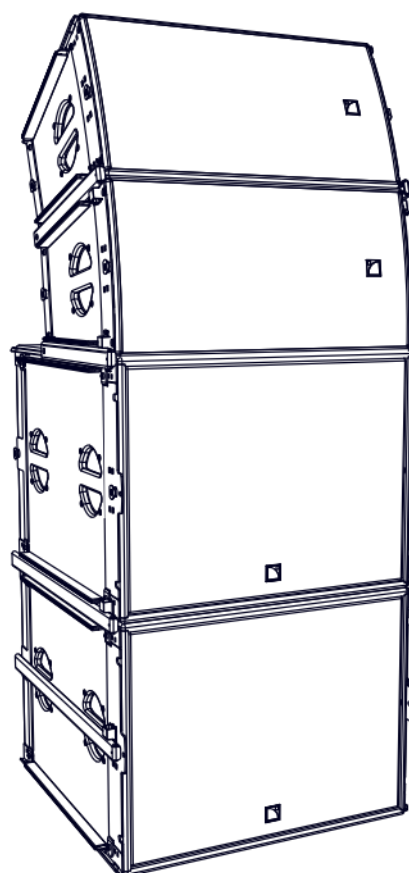
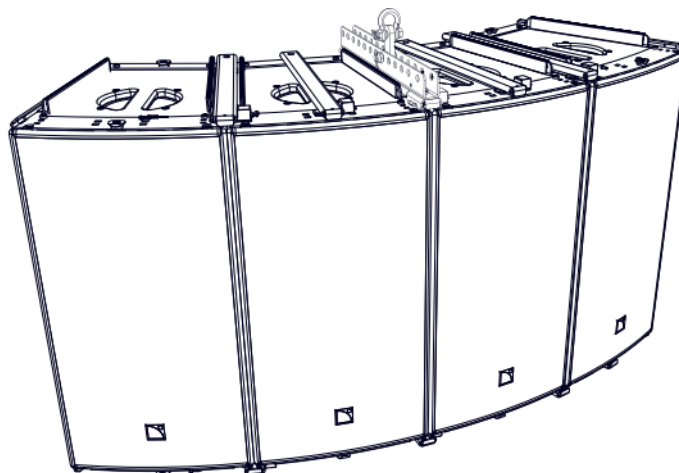
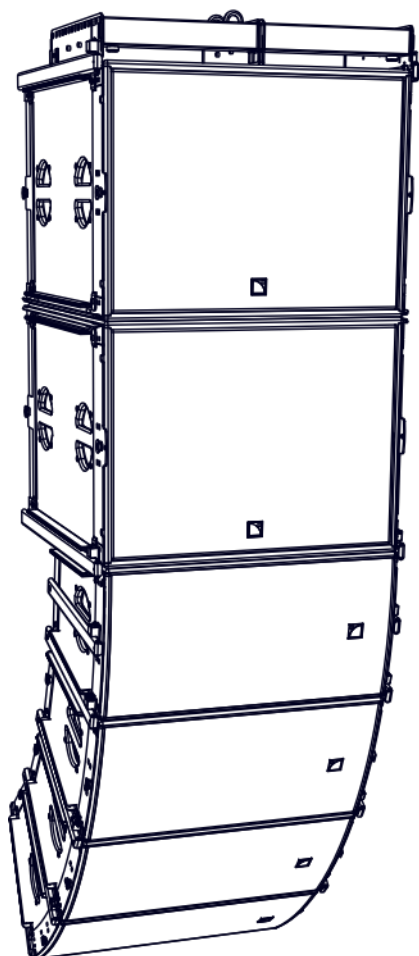

## **SAFETY INSTRUCTIONS**

- 1. Read this manual**
- 2. Follow all SAFETY INSTRUCTIONS as well as DANGER and OBLIGATION warnings**
- 3. Never incorporate equipment or accessories not approved by L-ACOUSTICS®**
- 4. Read all the related PRODUCT INFORMATION documents before exploiting the system**  
The product information document is included in the shipping carton of the related system component.
- 5. Work with qualified personnel for rigging the system**  
Installation should only be carried out by qualified personnel that are familiar with the rigging techniques and safety recommendations outlined in this manual.
- 6. Ensure personnel health and safety**  
During installation and set-up personnel must wear protective headgear and footwear at all times. Under no circumstances personnel is allowed to climb on a loudspeaker assembly.
- 7. Respect the Working Load Limit (WLL) of third party equipment**  
L-ACOUSTICS® is not responsible for any rigging equipment and accessories provided by third party manufacturers. Verify that the Working Load Limit (WLL) of the suspension points, chain hoists and all additional hardware rigging accessories is respected.
- 8. Respect the maximum configurations and the recommended safety level**  
For safety issue, respect the maximum configurations outlined in this manual. To check the conformity of any configuration in regards with the safety level recommended by L-ACOUSTICS®, model the system in SOUNDVISION and refer to the warnings in **Mechanical Data** section.
- 9. Be cautious when flying a loudspeaker array**  
Always verify that no one is standing underneath the loudspeaker array when it is being raised. As the array is being raised, check each individual element to make sure that it is securely fastened to the adjacent element. Never leave the array unattended during the installation process. As a general rule, L-ACOUSTICS® recommends the use of safety slings at all times.
- 10. Be cautious when ground-stacking a loudspeaker array**  
Do not stack the loudspeaker array on unstable ground or surface. If the array is stacked on a structure, platform, or stage, always check that the latter can support the total weight of the array. As a general rule, L-ACOUSTICS® recommends the use of safety straps at all times.
- 11. Take into account the wind effects on dynamic load**  
When a loudspeaker assembly is deployed in an open air environment, wind can produce dynamic stress to the rigging components and suspension points. If the wind force exceeds 6 bft (Beaufort scale), lower down and/or secure the loudspeaker array.

## **SYMBOLS**

The following symbols are used in this document:



### **DANGER**

This symbol indicates a potential risk of harm to an individual or damage to the product. It can also notify the user about instructions that must be strictly followed to ensure safe installation or operation of the product.



### **OBLIGATION**

This symbol notifies the user about instructions that must be strictly followed to ensure proper installation or operation of the product.



### **EQUIPMENT**

This symbol indicates the equipment, tools, and spare parts required to perform a procedure.



### **INFORMATION**

This symbol notifies the user about complementary information or optional instructions.



# WELCOME TO L-ACOUSTICS®

Thank you for choosing the L-ACOUSTICS® ARCS® WIDE SYSTEM or ARCS® FOCUS SYSTEM.

This document contains essential information on rigging the system properly. Carefully read this document in order to become familiar with this procedures.

As part of a continuous evolution of techniques and standards, L-ACOUSTICS® reserves the right to change the specifications of its products and the content of its documents without prior notice.

Please check the L-ACOUSTICS® web site on a regular basis to download the latest documents: [www.l-acoustics.com](http://www.l-acoustics.com).

## CONTENTS

<b>1</b>	<b>RIGGING SYSTEM COMPONENTS</b>	<b>4</b>
1.1	Loudspeaker enclosures .....	4
1.2	Rigging elements .....	4
1.3	Software application .....	4
<b>2</b>	<b>MECHANICAL SAFETY</b>	<b>6</b>
2.1	Maximum configurations .....	6
2.2	Assessing mechanical safety .....	7
<b>3</b>	<b>SYSTEM SETUP</b>	<b>8</b>
3.1	Ground-stacking .....	8
	Horizontal .....	8
	Horizontal stacked on SB18m .....	8
	Vertical stacked on SB18m .....	8
3.2	Flying.....	9
	WIFOLIFT position on array.....	9
	Horizontal 2 or 4 enclosure.....	11
	Horizontal 3, 5 or 6 enclosure.....	11
	Vertical.....	12
3.3	Pole-mounting .....	13
	On feet or on top of SB18m .....	13
<b>4</b>	<b>SUBSET PROCEDURES</b>	<b>14</b>
PROCEDURE A	Locking a rigging bar (WIFORIG, SB18MRIG or WIFOLIFT).....	14
PROCEDURE B	Attaching a WIFOLIFTBAR .....	15
	Description .....	15
	Tilt angle definition and rigging holes choice .....	15
	Procedure .....	17
PROCEDURE C	Attaching a shackle or CLAMP250.....	19
PROCEDURE D	Mounting the WIFOSOCK.....	21
<b>APPENDIX A</b>	<b>PULLBACK IMPLEMENTATION</b>	<b>22</b>
A.	Vertical Array.....	22
B.	Horizontal array.....	23
<b>APPENDIX B</b>	<b>TILT ANGLE REFERENCE CHARTS</b>	<b>24</b>
<b>APPENDIX C</b>	<b>RECOMMENDED FLIGHT-CASE</b>	<b>28</b>
<b>APPENDIX D</b>	<b>SPECIFICATIONS</b>	<b>29</b>
ARCS® FOCUS.....		29
ARCS® WIDE.....		30
SB18m .....		31
CLAMP250 .....		32
WIFOBUMP .....		32
WIFOLIFT .....		33
WIFOLIFTBAR .....		33
WIFOSOCK.....		33

## 1 RIGGING SYSTEM COMPONENTS

The system approach developed by L-ACOUSTICS® consists in providing packaged solutions for loudspeaker system in order to guarantee the highest and most predictable level of performance at any step: modeling, installation, and operation. An L-ACOUSTICS® loudspeaker system is the set of components available to form any loudspeaker system based on one of the full-range loudspeaker enclosure afforded by L-ACOUSTICS®. It includes enclosures, rigging accessories, loudspeaker cables, amplified controllers, and software applications.

The main components involved in the rigging process of an **ARCS® WIDE SYSTEM** or **ARCS® FOCUS SYSTEM** are the following:

### 1.1 Loudspeaker enclosures

---

ARCS® WIDE	Full range enclosure, arrayable in a constant curvature line, provided with 2 WIFORIG coupling bars.
ARCS® FOCUS	Full range enclosure, arrayable in a constant curvature line, provided with 2 WIFORIG coupling bars.
SB18m	Subwoofer enclosure provided with 2 SB18MRIG coupling bars.

### 1.2 Rigging elements

---

WIFOBUMP	Frame for flying ARCS® WIDE/FOCUS or SB18m enclosures as a vertical array. Provided with two bow shackles WLL 1 t.
WIFORIG	Coupling bars dedicated to ARCS® WIDE and ARCS® FOCUS. Equipped with the LOCKTAB locking tab. Delivered with the enclosures.
SB18MRIG	Coupling bars dedicated to SB18m. Equipped with the LOCKTAB locking tab. Delivered with the enclosure.
WIFOLIFT	Bar for flying two, four, six or eight ARCS® WIDE/FOCUS enclosures as a horizontal array. Provided with one bow shackle WLL 1 t and one connecting rod.
WIFOLIFTBAR	Bar for flying three, five or six ARCS® WIDE/FOCUS enclosures as a horizontal array. Provided with one bow shackle WLL 1 t.
WIFOSOCK	Pole mount socket for an ARCS® WIDE/FOCUS enclosure.
CLAMP250	Truss clamp.

### 1.3 Software application

---

SOUNDVISION	Proprietary 3D acoustical and mechanical modeling software.
-------------	---



#### **Mechanical safety**

Before any installation, model the system in SOUNDVISION and check the **Mechanical Data** section for any *stress warnings*.



#### **Other ARCS® WIDE/FOCUS SYSTEM components**

All the other components of the system are presented in the **ARCS® WIDE/FOCUS SYSTEM user manual**, document in which the loudspeaker configurations and connection are described.



**ARCS® WIDE**



**ARCS® FOCUS**



**WIFOBUMP**



**SB18m**



**WIFOLIFT**



**WIFOSOCK**



**CLAMP250**



**WIFOLIFTBAR**



**WIFORIG**



**SB18MRIG**



**SOUNDVISION**



**SB18PLA**



**SB18COV**

**Components involved in the rigging process of ARCS® WIDE SYSTEM / ARCS® FOCUS SYSTEM**

## 2 MECHANICAL SAFETY

### 2.1 Maximum configurations

The ARCS® WIDE/FOCUS rigging system complies with BGV-C1 (2013), DIN 18800 and EN ISO 12100-1 (2004) when the following arrays are deployed.

The **safe configurations** are always compliant with the standards listed before, regardless of the chosen deployment parameters (site angles, inter-enclosure angles, etc.).

The **maximum configurations** correspond to the mechanical limit of the rigging accessories, before deploying these configurations always model the system in SOUNDVISION and check the **Mechanical Data** section for any *stress warning* or *stability warning*.

For mixed arrays always refer to your SOUNDVISION model.

		<b>Safe</b>	<b>Maximum</b>
Flying	WIFOLIFTBAR	5 ARCS® WIDE/FOCUS	6 ARCS® WIDE or 5 ARCS® FOCUS
	WIFOLIFTBAR + CLAMP250	5 ARCS® WIDE/FOCUS	6 ARCS® WIDE or 5 ARCS® FOCUS
	WIFOLIFT	4 ARCS® WIDE/FOCUS per WIFOLIFT	
	WIFOLIFT + CLAMP250		
Ground- stacking	WIFORIG	12 ARCS® WIDE 24 ARCS® FOCUS	



**6 ARCS® WIDE with WIFOLIFTBAR**

When flying 6 ARCS® WIDE enclosures with the WIFOLIFTBAR, only use holes n° 2,3,4,5,6 of the WIFOLIFTBAR.

		<b>Safe</b>	<b>Maximum</b>
Flying	WIFOBUMP	8 ARCS® WIDE/FOCUS or 4 SB18m	
	WIFOBUMP + CLAMP250	6 ARCS® WIDE/FOCUS or 3 SB18m	
Ground- stacking	WIFORIG	2 ARCS® WIDE/FOCUS on top of 2 SB18m	



**Maximum 4 ARCS® WIDE/FOCUS under SB18m**

In a flown hybrid vertical configuration never attach more than four ARCS® WIDE/FOCUS enclosures under the SB18m subwoofers.



**Mechanical safety of the rigging system**

Before any installation, always model the system in SOUNDVISION and check the **Mechanical Data** section for any *stress warning* or *stability warning*.

## 2.2 Assessing mechanical safety

---

In order to assess the actual safety of any array configuration before implementation, refer to the following warnings:



### **Rated working load limit (WLL) is not enough**

The rated WLL is an indication of the element resistance to tensile stress. For complex mechanical systems such as loudspeaker arrays, WLLs cannot be used per se to determine the maximum number of enclosures within an array or to assess the safety of a specific array configuration.



### **Mechanical modeling with SOUNDVISION**

The working load applied to each linking point, along with the corresponding safety factor, will depend on numerous variables linked to the composition of the array (type and number of enclosures, splay angles) and the implementation of the flying or stacking structure (number and location of flying points, site angle). This cannot be determined without the complex mechanical modeling and calculation offered by SOUNDVISION.



### **Assessing the safety with SOUNDVISION**

The overall safety factor of a specific mechanical configuration always corresponds to the lowest safety factor among all the linking points. Always model the system configuration with the SOUNDVISION software and check the **Mechanical Data** section to identify the weakest link and its corresponding working load. By default, a *stress warning* will appear when the mechanical safety goes beyond the recommended safety level.



### **Safety of ground-stacked arrays in SOUNDVISION**

For ground-stacked arrays, a distinct *stability warning* is implemented in SOUNDVISION. It indicates a tipping hazard when the array is not secured to the ground, stage or platform. It is user responsibility to achieve full anchorage and to ignore this warning.



### **Consideration must be given to unusual conditions**

SOUNDVISION calculations are based upon usual environmental conditions. A higher safety factor is recommended with factors such as extreme high or low temperatures, strong wind, prolonged exposition to salt water, etc. Always consult a rigging specialist to adopt safety practices adapted to such a situation.

### 3 SYSTEM SETUP

#### 3.1 Ground-stacking

**Horizontal**

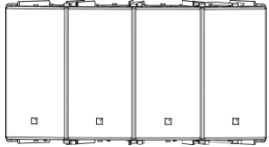

- ▶ Place the enclosures side-by-side, logo down, with their rails aligned.
- ▶ Remove the top coupling bars from their storage location.
- ▶ Slide and lock the bars into all top adjacent rails.
- ❗ Refer to **PROCEDURE A**.

**Horizontal stacked on SB18m**

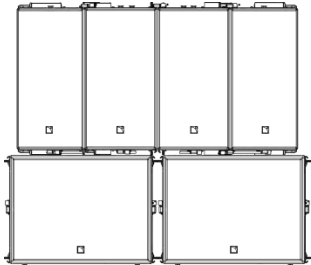

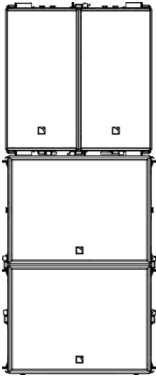

- ▶ Place two SB18m side-by-side or on top of each other, logo down.
- ▶ If the SB18m enclosures are vertically stacked:
  - ▶ Remove the SB18MRIG bars from their location.
  - ▶ Slide the bars on the subwoofers rails.
- ❗ Refer to **PROCEDURE A**.
- ▶ Place the ARCS® WIDE/FOCUS enclosures on top of the subwoofers, side-by-side with rails aligned.
- ▶ Remove the top WIFORIG bars from their storage location.
- ▶ Slide and lock the WIFORIG bars on the top adjacent ARCS® WIDE/FOCUS rails.
- ❗ Refer to **PROCEDURE A**.

**Vertical stacked on SB18m**

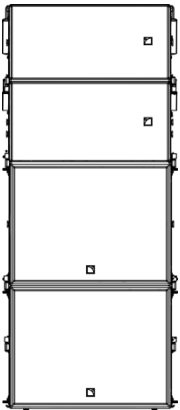

- ▶ Place two SB18m (logo down) on top of each other.
- ▶ Remove the SB18MRIG bars from their location.
- ▶ Slide the bars on the subwoofers rails.
- ❗ Refer to **PROCEDURE A**.
- ▶ Place the ARCS® WIDE/FOCUS enclosures with rails aligned on top of the subwoofers.
- ▶ Remove the top WIFORIG bars from their storage location
- ▶ Slide and lock the bars on the ARCS® WIDE/FOCUS adjacent rails.
- ❗ Refer to **PROCEDURE A**.



## 3.2 Flying

### WIFOLIFT position on array

The **WIFOLIFT** alone is used to fly:

- two or four enclosures with one load-bearing line or
- four or six enclosures with two load-bearing lines.



Refer to the figures below for the position and number of **WIFOLIFT** required in an horizontal array with an even number of enclosures.

1 WIFOLIFT for 2 or 4 enclosures

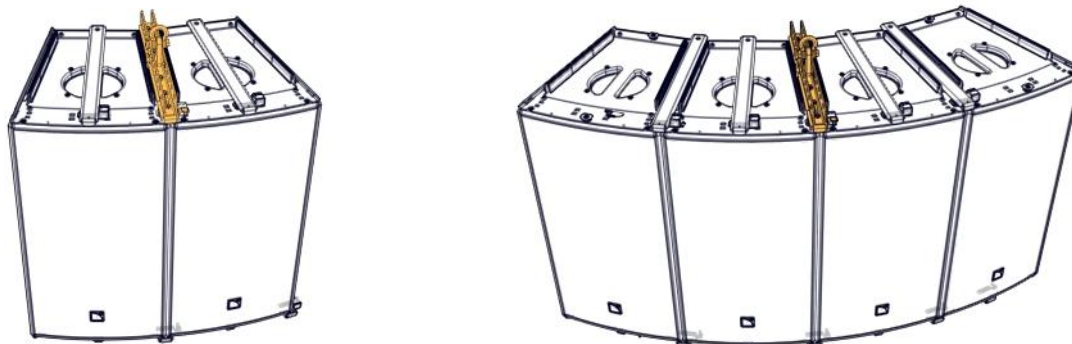

2 WIFOLIFT for 6 or 8 enclosures



**No bridled suspension on two WIFOLIFT bars.**  
Always use 1 load-bearing line per pick-up point.

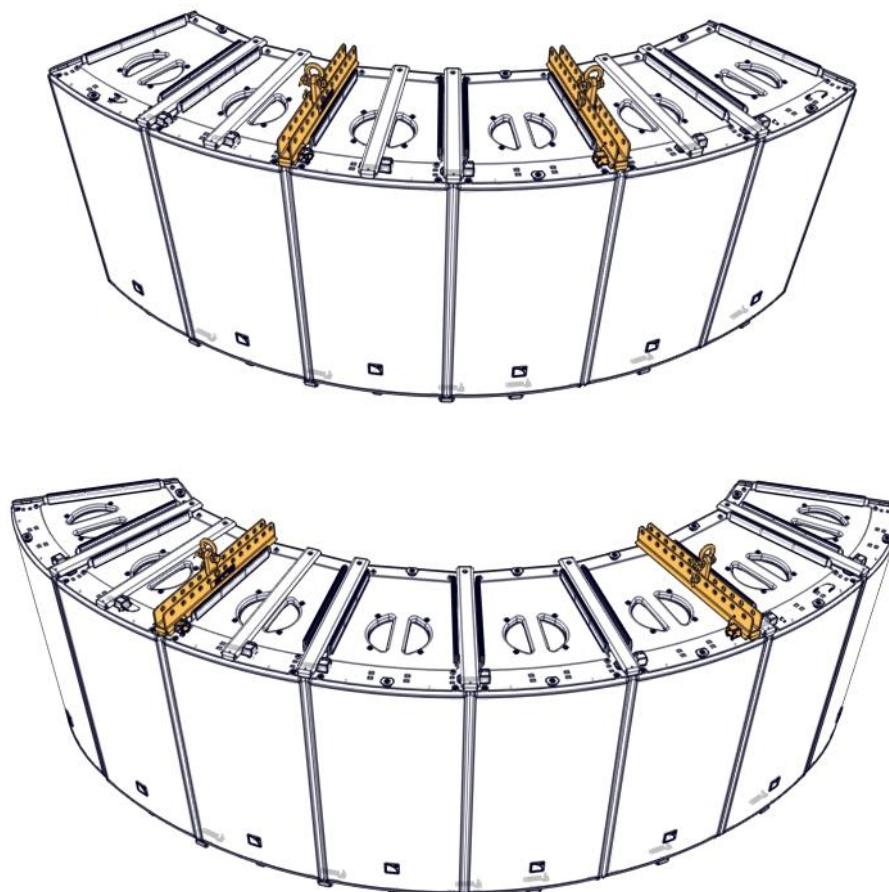

The **WIFOLIFTBAR** combined with **two WIFOLIFT** is used to fly:

- three or five enclosures with one load-bearing line *or*
- six ARCS® WIDE with one load-bearing line.



Refer to the indication below for the position and number of **WIFOLIFT** and **WIFOLIFTBAR** required in an horizontal array with an uneven number of enclosures.

2 WIFOLIFT and 1 WIFOLIFTBAR for 3, 5 or 6 enclosures

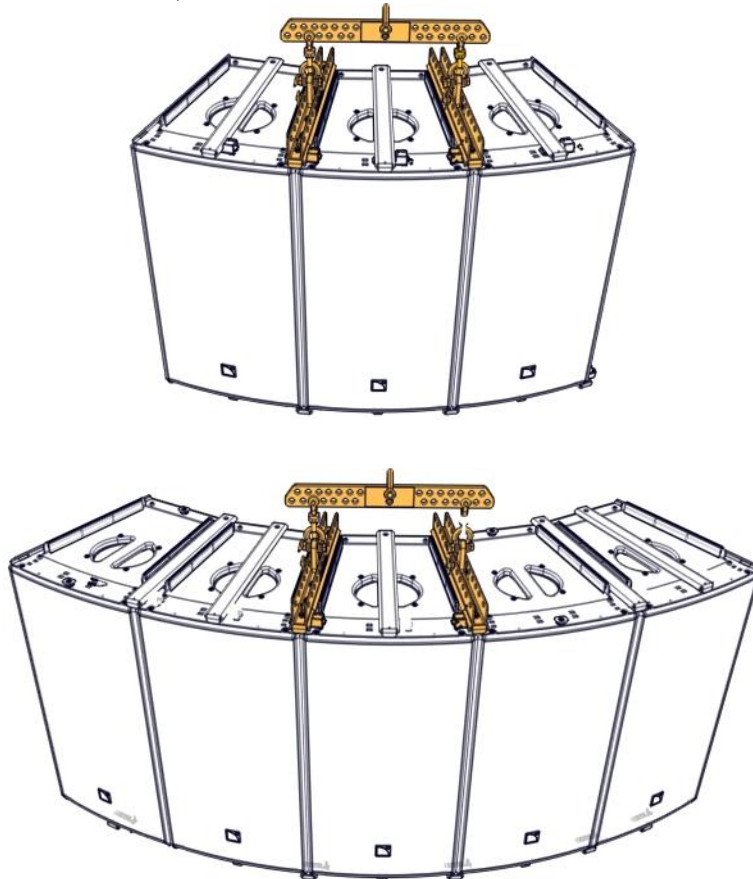

**ARCS® WIDE only**

When used with 6 enclosures, the WIFOLIFTBAR is only compatible with ARCS® WIDE.

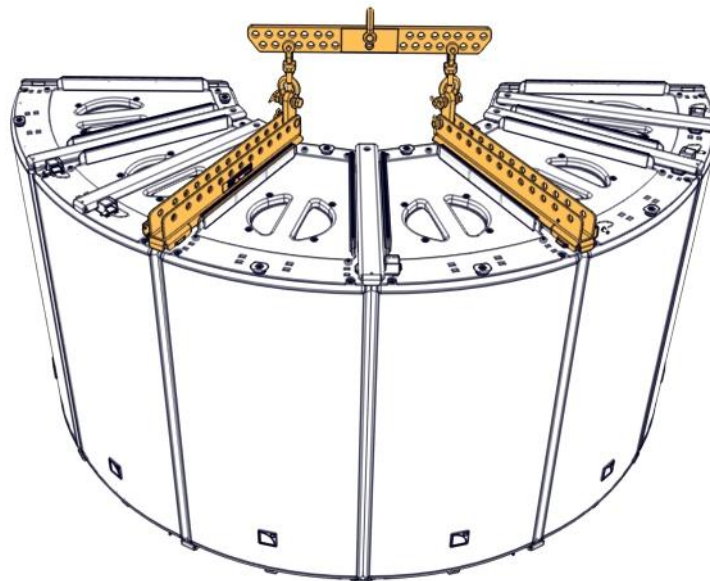



**No bridled suspension on two WIFOLIFT bars.**

Always use 1 load-bearing line per pick-up point.

**Pullback implementation**

By using rigging points at the rear of the installed coupling bars, an ARCS® WIDE/FOCUS horizontal or vertical array can be implemented in pullback configuration. Refer to **APPENDIX A**.

**Final check before flying the system**

Coupling bars: All lugs of locking tabs must be secured, as indicated in **PROCEDURE A**.

Shackles: All safety pins must be secured as indicated in **PROCEDURE C**.



**Truss clamping**

By installing a CLAMP250 instead of a shackle, an array can be attached to a truss.

Refer to **PROCEDURE B**.

**Horizontal 2 or 4 enclosure**

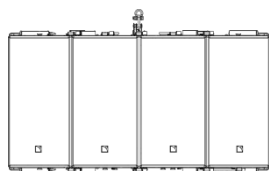

- ▶ Place the enclosures in vertical position, side-by-side, logo down and rails aligned.
- ▶ Remove all top WIFORIG bars from their storage location.
- ▶ Install the WIFOLIFT bar(s).  
See WIFOLIFT position on array au-dessus at the beginning of this section.
- ❗ Refer to **PROCEDURE A**.
- ▶ Slide and lock the WIFORIG bars into all top remaining adjacent rails.
- ❗ Refer to **PROCEDURE A**.
- ▶ Attach a shackle on each of the WIFOLIFT bars.
- ❗ Refer to **PROCEDURE B**.
- ▶ Slightly raise the array.
- ▶ Remove all bottom WIFORIG bars from their storage location.
- ▶ Slide and lock WIFORIG bars into all bottom adjacent rails.
- ❗ Refer to **PROCEDURE A**.



**WIFOLIFTBAR positioning**

Refer to WIFOLIFT position on array on page 9-10.

**Hybrid arrays**

If you are implementing a hybrid configuration carefully follow the verification procedure outlined in **PROCEDURE B Attaching a WIFOLIFTBAR**.

**Horizontal 3, 5 or 6 enclosure**

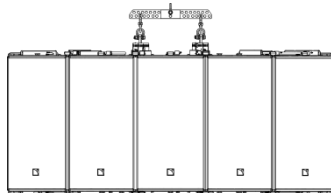

- ▶ Place the enclosures in vertical position, side-by-side, logo down and rails aligned.
- ▶ Remove all top WIFORIG bars from their storage location.
- ▶ Install the WIFOLIFT bar(s).  
See WIFOLIFT position on array at the beginning of this section.
- ❗ Refer to **PROCEDURE A**.
- ▶ Slide and lock the WIFORIG bars into all top remaining adjacent rails.
- ❗ Refer to **PROCEDURE A**.
- ▶ Attach a WIFOLIFTBAR to the two WIFOLIFT.
- ❗ Refer to **PROCEDURE B**.
- ▶ Attach a shackle or a CLAMP250 to the WIFOLIFTBAR.
- ❗ Refer to **PROCEDURE C**.
- ▶ Slightly raise the array.
- ▶ Remove all bottom WIFORIG bars from their storage location.
- ▶ Slide and lock WIFORIG bars into all bottom adjacent rails.
- ❗ Refer to **PROCEDURE A**.



#### No bridled suspension on the WIFOBUMP frame

Always use 1 load-bearing line per pick-up point.

#### Pullback implementation

By using rigging points at the rear of the installed coupling bars, an ARCS® WIDE/FOCUS horizontal or vertical array can be implemented in pullback configuration. Refer to **APPENDIX A**.

#### Final check before flying the system

Coupling bars: All lugs of locking tabs must be secured, as indicated in **PROCEDURE A**.

Shackles: All safety pins must be secured as indicated in **PROCEDURE C**.



#### Truss clamping

By installing a CLAMP250 instead of a shackle, an array can be attached to a truss.  
Refer to **PROCEDURE B**.

### Vertical

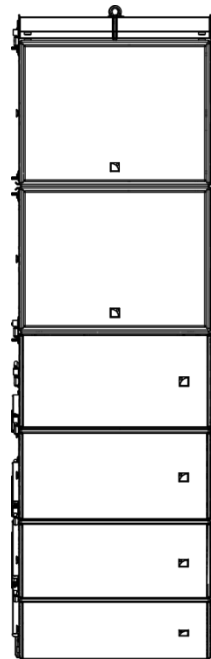
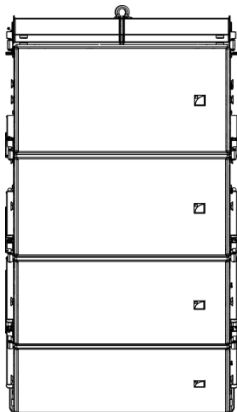

- ▶ Place the first enclosure (WIDE, FOCUS or SB18m) on the floor.
- ▶ For an array with 2 SB18m, place and lock a second SB18m on top of the first one.
- ⓘ Refer to **PROCEDURE A** to lock the SB18MRIG bars.
- ▶ Remove the top coupling bars from their storage location.
- ▶ Place the WIFOBUMP frame on the top enclosure and lock the coupling bars.  
With an SB18m on top, refer to SOUNDVISION for the frame position (front or rear).
- ⓘ Refer to **PROCEDURE A** to lock the coupling bars.
- ▶ Attach a shackle on the WIFOBUMP.
- ⓘ Refer to **PROCEDURE B**.
- ▶ Raise the array so you are comfortable lifting and attaching the next enclosure.
- ▶ Bring the next enclosure and remove the bars from their storage location.
- ▶ With the rigging bar in hand, lift the next enclosure and attach it under the array.
- ⓘ Refer to **PROCEDURE A** to lock the coupling bars.
- ▶ To add more enclosures, repeat the previous 3 steps until the array is completed.

### 3.3 Pole-mounting

**On feet or on top of SB I 8m**

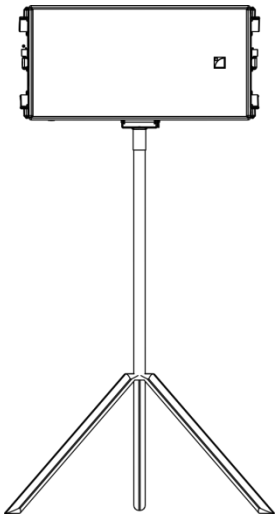
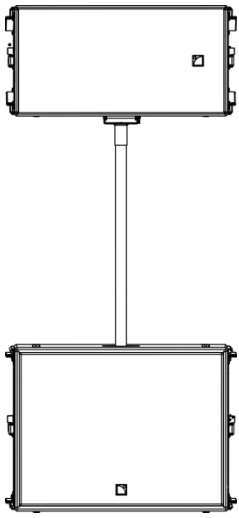
- ▶ Install a WIFOSOCK on an ARCS® WIDE/FOCUS enclosure.
- ❗ Refer to **PROCEDURE D**.
- ▶ Insert the pole into the WIFOSOCK socket.
- ▶ If needed, insert the other extremity of the pole into an SB I 8m socket.
- ▶ Tip the assembly to a vertical position.



#### **Dismantling the system**

Identify the array to dismount and apply the associated System setup procedure in reversed order.

## 4 SUBSET PROCEDURES

### PROCEDURE A Locking a rigging bar (WIFORIG, SB18MRIG or WIFOLIFT)



#### Coupling bars and SB18m

Only use the longer SB18MRIG bars stored on the SB18m subwoofers to attach SB18m to another SB18m or to a WIFOBUMP.

The shorter WIFORIG bars do not ensure the mechanical safety of these connections.

1. Remove the bar from its storage location.
2. From the front of the array, slide the bar into adjacent rigging rails.
3. Secure the bar with the locking tab.
  - a. Accurately position the bar by pushing it into place.
  - b. Pinch the spring tongue and slide the locking tab until it snaps into place.  
When encountering difficulty, try to slide the tab from the other side.
  - c. Verify that the yellow label is fully covered to ensure of the locking tab is engaged.

#### ► PROCEDURE A: Locking a rigging bar

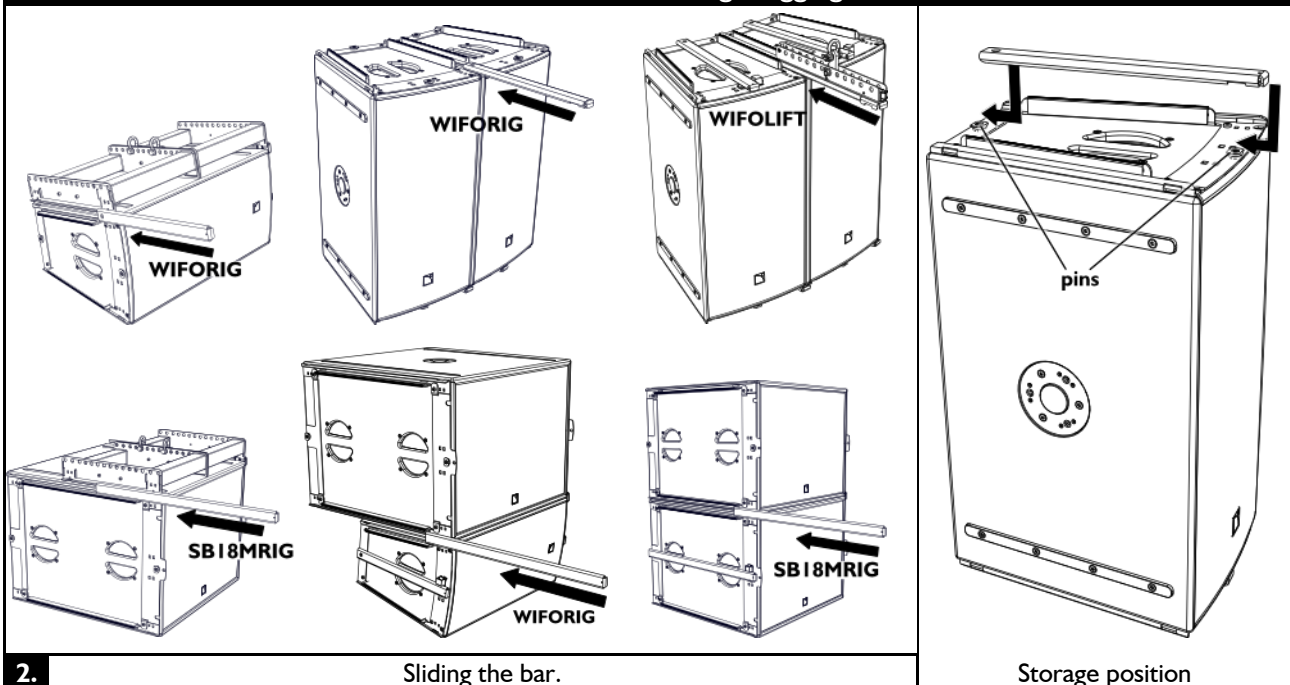

2. Sliding the bar.

Storage position

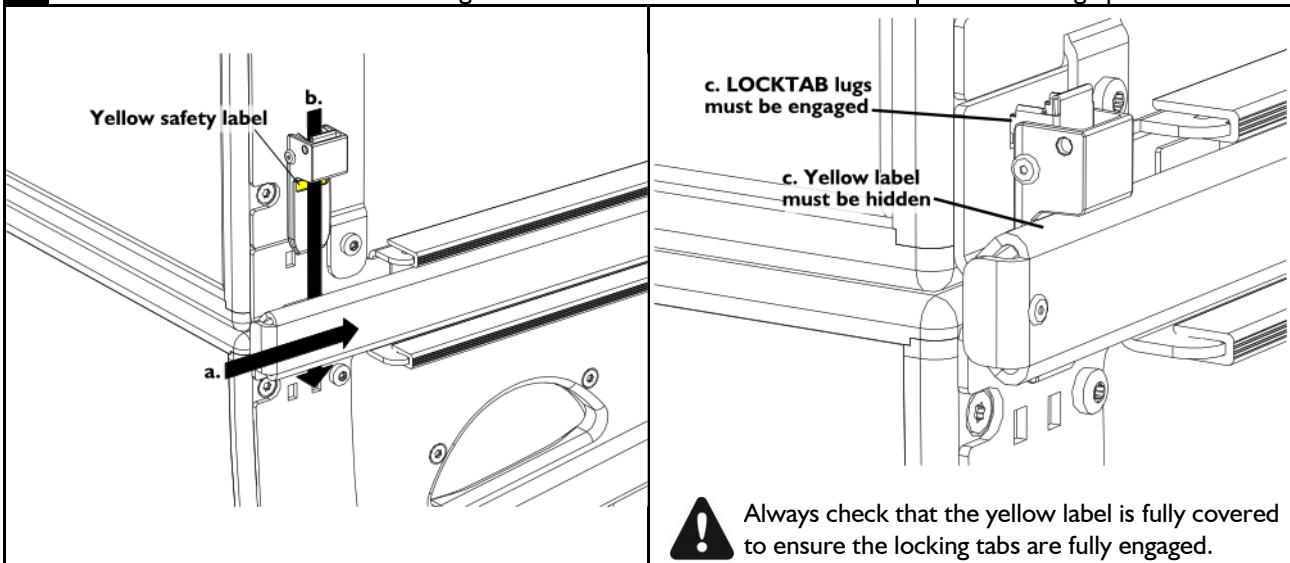

3. Securing the bar with the locking tab.



## PROCEDURE B Attaching a WIFOLIFTBAR

### Description

The WIFOLIFTBAR is a rigging accessory used to fly 3 or 5 ARCS® WIDE/FOCUS or 6 ARCS® WIDE.

It is used with two WIFOLIFT that are positioned on the array depending on the number of enclosures, see [WIFOLIFT position on array](#) (page 9).

The WIFOLIFTBAR is composed of a metal bar with two rows of 15 holes and 2 swivel shackles. It can be used with a bow shackle WLL 1 t or a CLAMP250 attached to one of the two central holes. The swivel shackles can be attached the other 28 holes to connect the WIFOLIFTBAR to the two WIFOLIFT.

### Tilt angle definition and rigging holes choice

The tilt angle of an array is defined by the holes selected on the WIFOLIFT.

**For homogeneous arrays** (ARCS® WIDE or FOCUS), refer to the **Tilt angle reference chart** on the next page to define which WIFOLIFT holes correspond to your target tilt angle and which WIFOLIFTBAR holes to use.

For example, rigging a three ARCS® FOCUS array on holes n° 1 on the WIFOLIFT yield a 26.5° positive angle and requires attaching the swivel shackles to holes n° 2 on the WIFOLIFTBAR.

**For hybrid arrays** (ARCS® WIDE and FOCUS), a trial-and-error process must be applied to define the appropriate WIFOLIFT and WIFOLIFTBAR holes.

The goal is to reduce the stress on the WIFOLIFT to a minimum:

- the rigging arm and the swivel shackle must be aligned
- the WIFOLIFT bar must remain parallel to the top of the array.

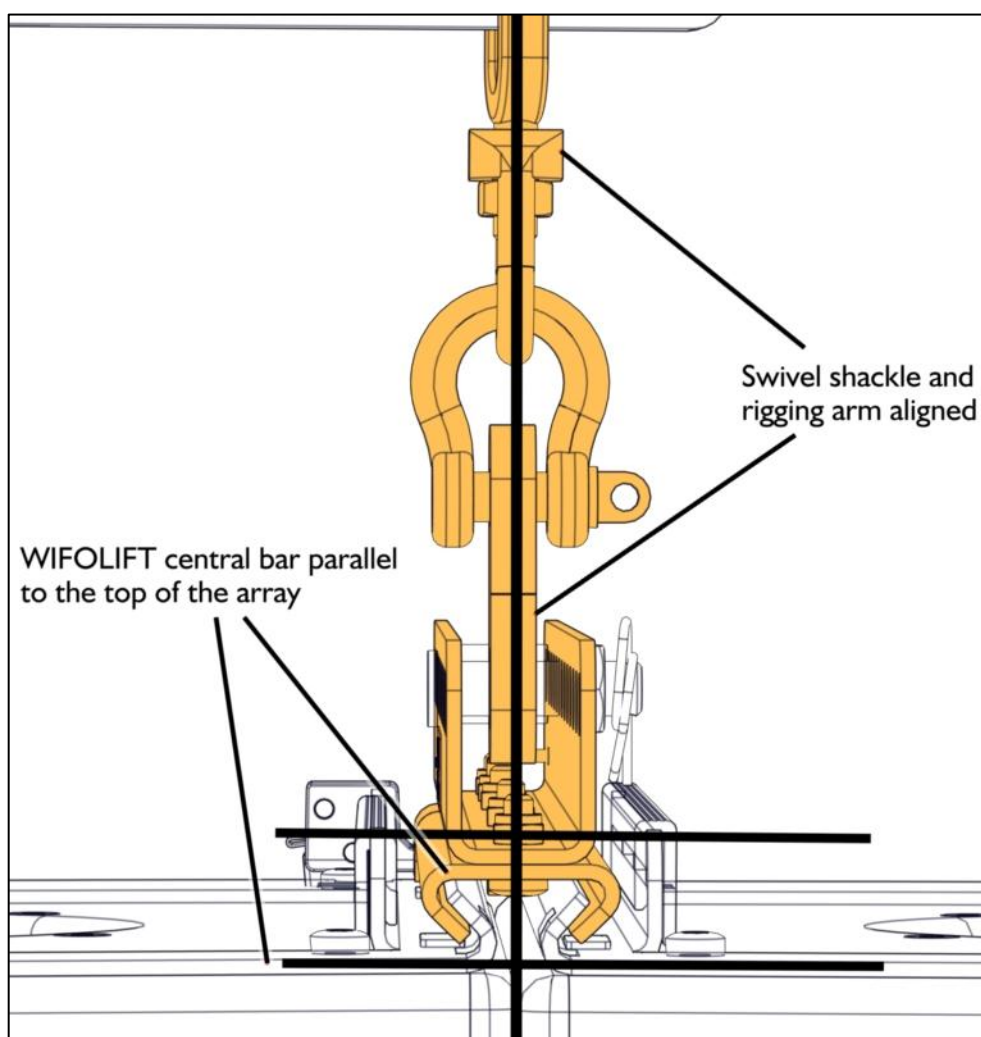

Tilt angle reference chart WIFOLIFTBAR

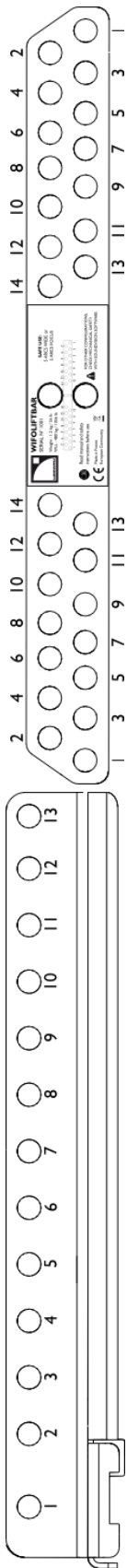

WIFOLIFT hole	3 ARCS® FOCUS		3 ARCS® WIDE		5 ARCS® FOCUS		5 ARCS® WIDE		6 ARCS® WIDE	
	WIFOLIFTBAR HOLE	Tilt angle	WIFOLIFTBAR HOLE	Tilt angle	WIFOLIFTBAR HOLE	Tilt angle	WIFOLIFTBAR HOLE	Tilt angle	WIFOLIFTBAR HOLE	Tilt angle
1	2	26,5°	2	26,0°	2	32,3°	1	34,7°		
2	3	21,6°	3	21,8°	3	28,0°	2	30,9°		
3	3	17,6°	4	17,9°	3	24,4°	3	27,5°		
4	4	13,4°	5	13,8°	4	20,4°	4	23,9°		
5	5	9,0°	6	9,5°	4	16,4°	5	20,2°		
6	5	4,8°	7	4,4°	5	12,1°	6	16,3°		
7	6	0,2°	8	1,1°	5	7,8°	7	12,4°		
8	6	-4,4°	9	-3,2°	6	3,3°	9	8,2°		
9	7	-8,9°	10	-7,4°	6	-1,3°	10	4,0°	2	5,1°
10	7	-13,1°	11	-11,7°	7	-5,7°	11	-0,1°	3	1,4°
11	8	-17,3°	12	-15,7°	7	-10,0°	12	-4,3°	4	-2,2°
12	8	-21,4°	13	-19,7°	8	-14,4°	13	-8,8°	5	-5,7°
13	9	-25,0°	14	-23,1°	8	-18,2°	14	-12,5°	6	-9,3°

☐ = not applicable



## Procedure

If you are raising a hybrid array (ARCS® WIDE and FOCUS), follow these steps:

1. Select the WIFOLIFT and WIFOLIFTBAR holes to define a starting point.  
The values given in the [Tilt angle reference chart](#) can be used as a guideline.  
Select the array which composition is the closest to your hybrid array and use the indicated WIFOLIFT and WIFOLIFTBAR.  
For example, to reach a 0,2° tilt angle with an array of 2 ARCS® WIDE and 1 ARCS® FOCUS, refer to the 3 ARCS® WIDE array and use WIFOLIFT hole n° 7 and WIFOLIFTBAR hole n° 8.
2. Attach two swivel shackles to the indicated holes on a WIFOLIFTBAR.
3. Attach the WIFOLIFTBAR to the indicated hole on the two WIFOLIFT.
  - a. Attach a rigging arm to the selected hole on each WIFOLIFT by driving and securing the pierced bolt.
  - b. Pass the U-shaped part of the shackle through the swivel shackle loop.
  - c. Attach the bow shackle to the arm.
  - d. Secure the shackle.
4. Raise the array so you can measure the angle.  
*If you are not satisfied*, lower the array to the ground and adjust the angle by picking another hole.  
*If you are satisfied* with the angle, continue.



### Risk of fall.

The WIFOLIFT must be parallel to the top of the array. Any other situation creates mechanical stress and can cause the WIFOLIFT to pop out.

5. Verify that the central bar of the two WIFOLIFT is parallel to the top of the array.  
*If it is parallel*, the array is ready.  
*If it is not parallel*, follow these steps:
  - a. Lower the array to the ground.
  - b. Change the swivel shackles rigging holes on the WIFOLIFTBAR so that the rigging arm and the swivel shackle form a straight line.
  - c. Repeat step 5 until the central bar of the WIFOLIFT is parallel to the top of the array.

If you are raising an homogeneous array,

1. Select the appropriate WIFOLIFT and WIFOLIFTBAR holes using the [Tilt angle reference chart](#) on the previous page
2. Attach two swivel shackles to the indicated holes on a WIFOLIFTBAR.
3. Attach the WIFOLIFTBAR to the indicated hole on the two WIFOLIFT.
  - a. Attach a rigging arm to the WIFOLIFT hole by driving and securing the pierced bolt.
  - b. Pass the U-shaped part of the shackle through the swivel shackle loop.
  - c. Attach the bow shackle to the arm.
  - d. Secure the shackle.

#### ► PROCEDURE D: Attaching a WIFOLIFTBAR

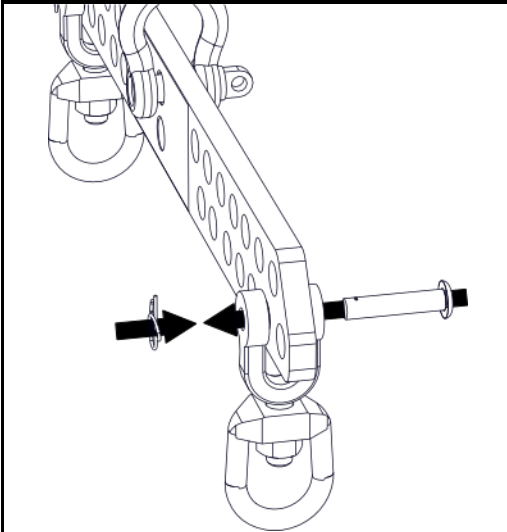

Securing a swivel shackle on WIFOLIFTBAR.

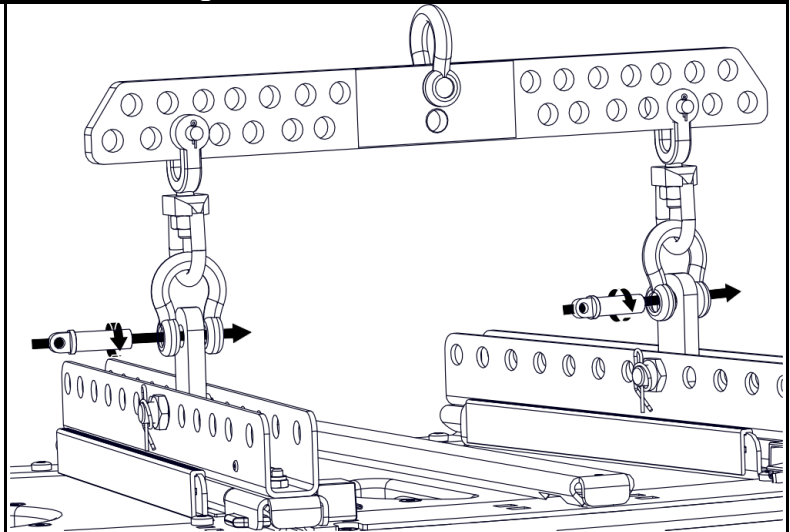

Securing the WIFOLIFTBAR to the two WIFOLIFT.

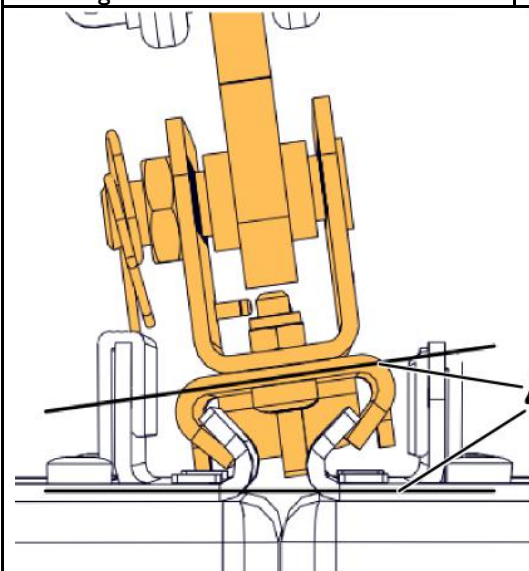

⚠ These two surfaces must be parallel.

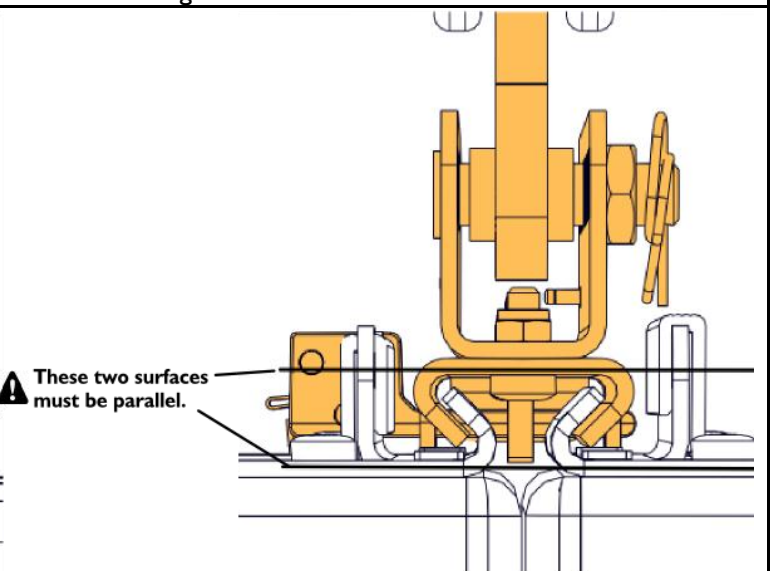

Verifying the WIFOLIFT central bar is parallel to the top of the array.

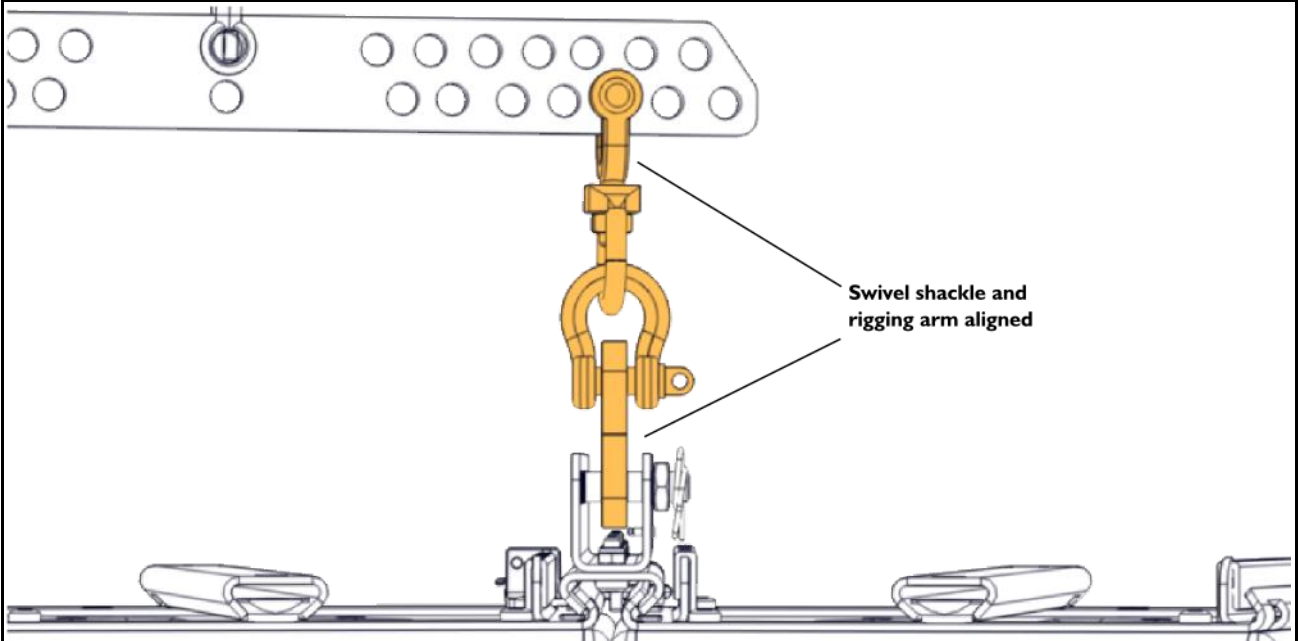

Swivel shackle and rigging arm aligned

Verifying the alignment of the swivel shackle and the rigging arm.

## PROCEDURE C Attaching a shackle or CLAMP250

1. Refer to **SOUNDVISION** modeling or to the table in **APPENDIX B TILT ANGLE REFERENCE CHART** to identify the hole that corresponds to the targeted tilt angle.

### WIFOBUMB HOLES

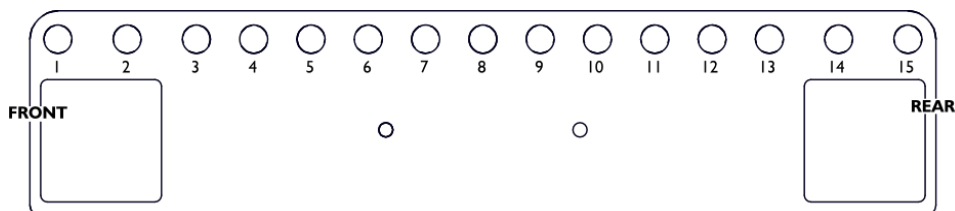

### WIFOLIFT HOLES

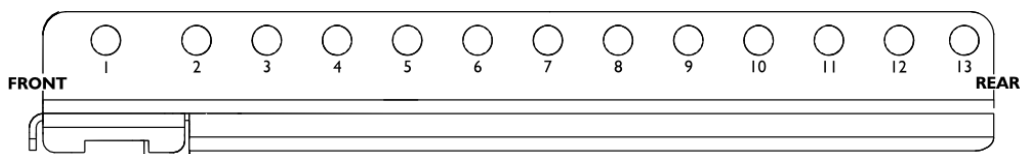

### WIFOLIFTBAR HOLES

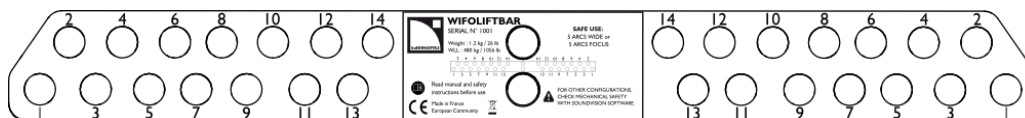

#### About site angle

Since many variables can affect the actual site angle, it is recommended to use an inclinometer.

2. Attach a shackle or a CLAMP250 to the identified hole, by driving the pierced bolt.
3. Secure the shackle.
4. With a CLAMP250, install safety slings between the KIBU-SB and the truss.

### ► PROCEDURE C: Attaching a shackle or a CLAMP250

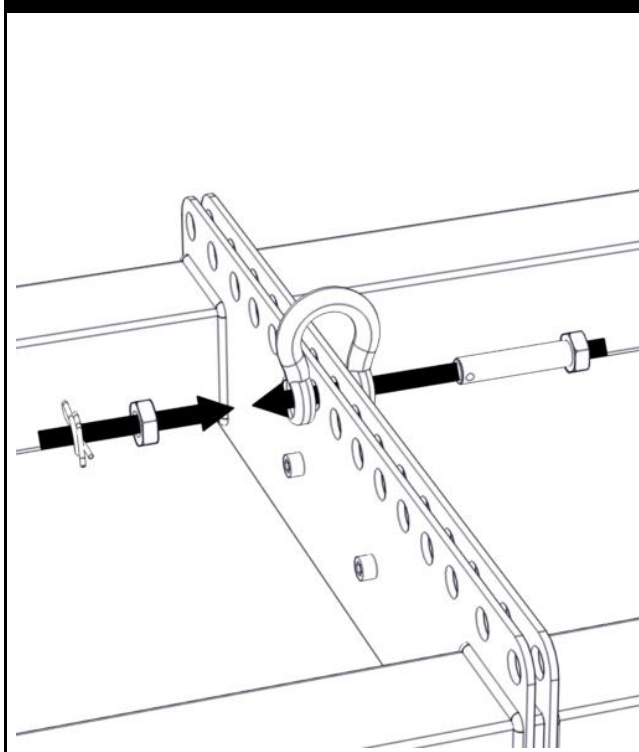

A shackle being attached on the WIFOBUMP.

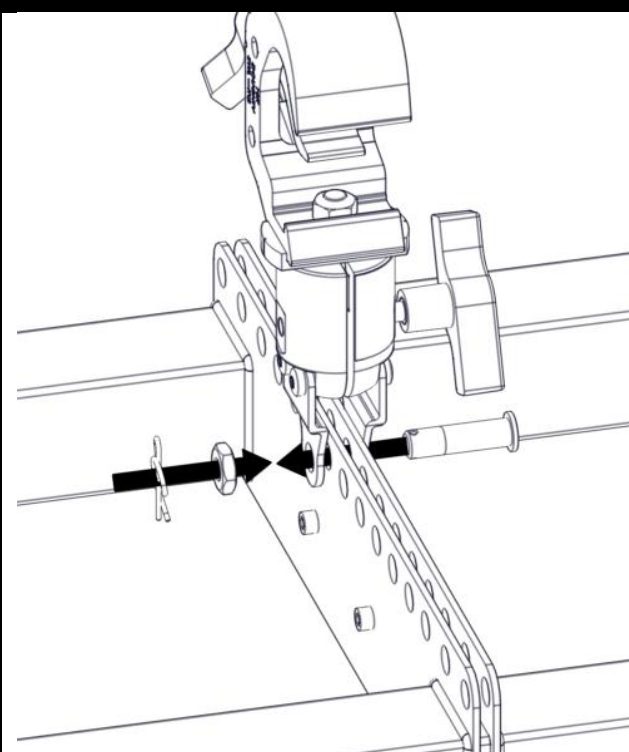

2. A CLAMP250 being attached on the WIFOBUMP.

#### ► PROCEDURE C: Attaching a shackle or a CLAMP250

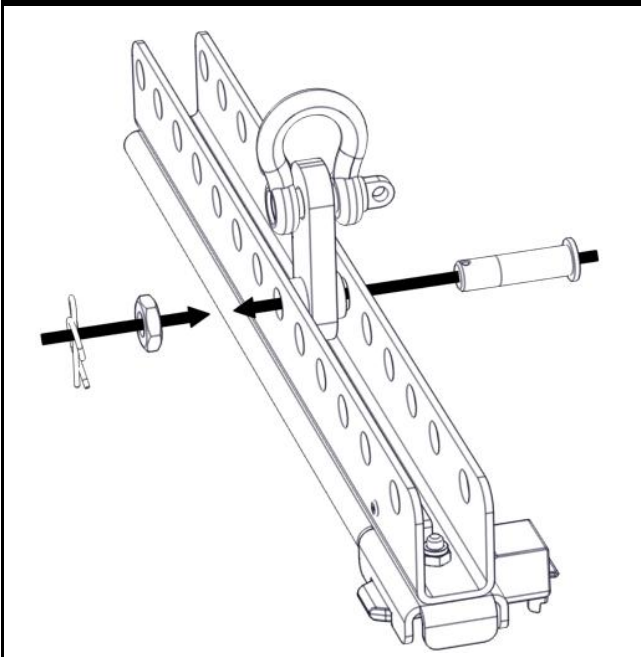

A shackle being attached on the WIFOLIFT.

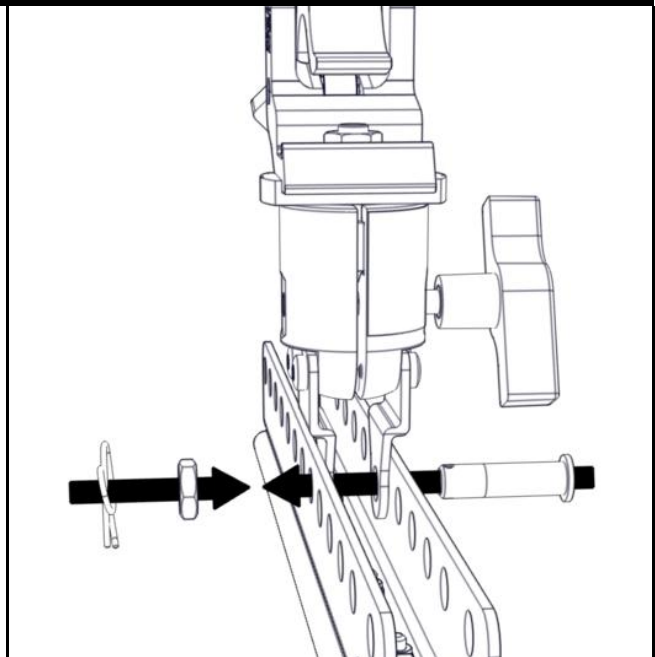

2. A CLAMP250 being attached on the WIFOLIFT.

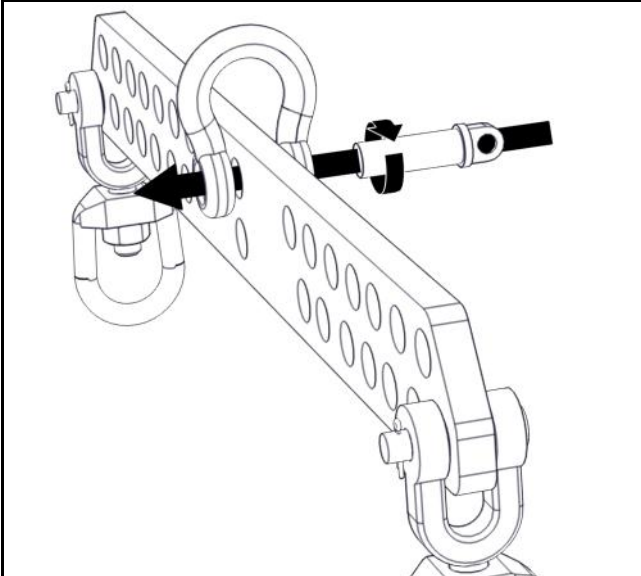

A shackle being attached on the WIFOLIFTBAR.

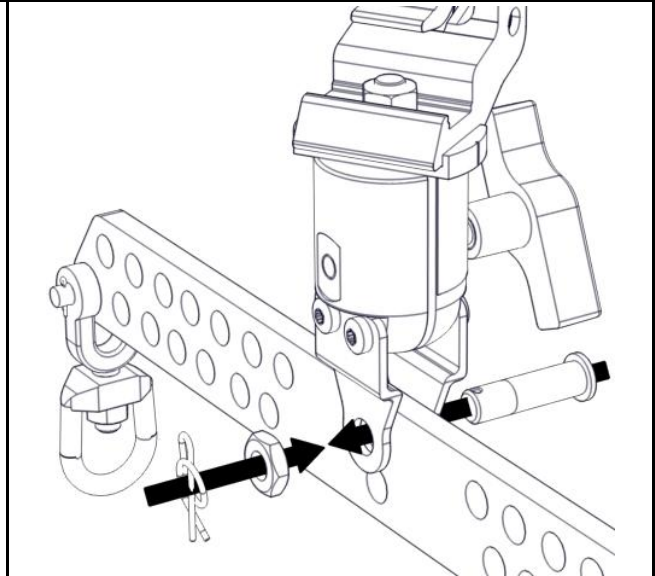

2. A CLAMP250 being attached on the WIFOLIFTBAR.

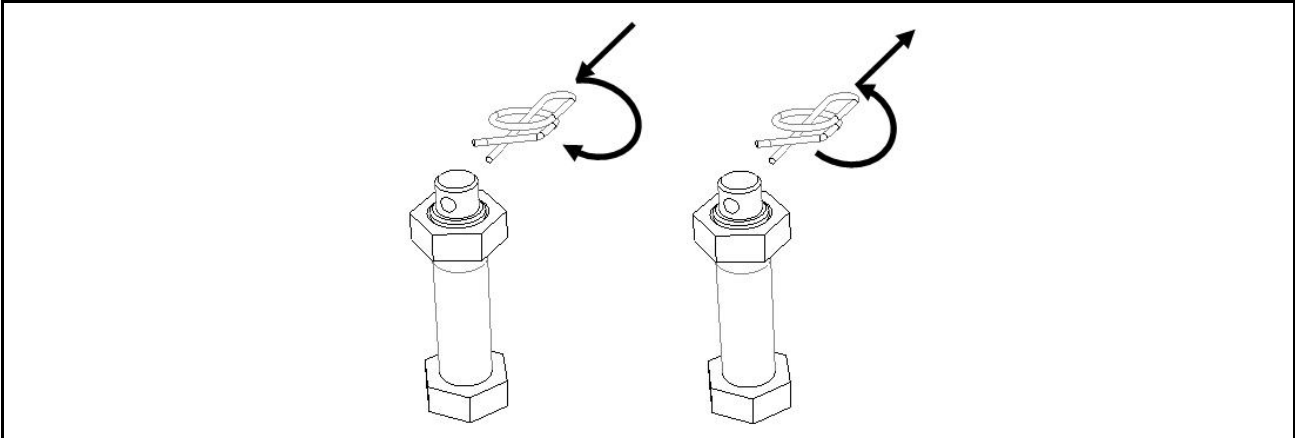

3.

Safety pin mechanism on shackles.

## PROCEDURE D Mounting the WIFOSOCK

1. Remove the pin from the angle hole.
2. Place the WIFOSOCK onto the socket receptacle of the enclosure.
3. Secure the WIFOSOCK by applying a quarter-turn rotation to the three screws, with a coin or a screwdriver.
4. Insert the pin into the appropriate angle hole.

### ► PROCEDURE D: Mounting the WIFOSOCK socket

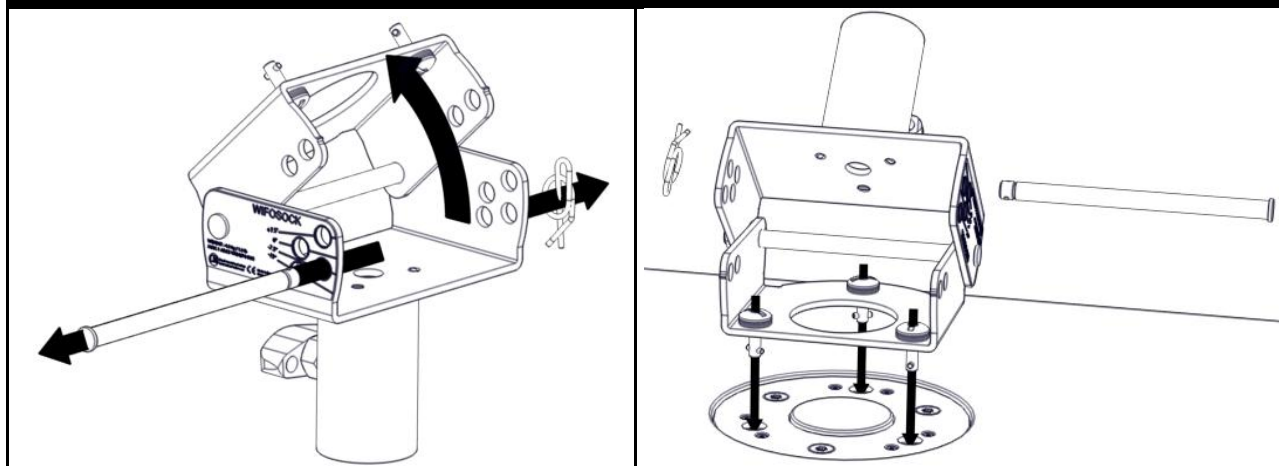

1. The pin being removed

2. WIFOSOCK being placed

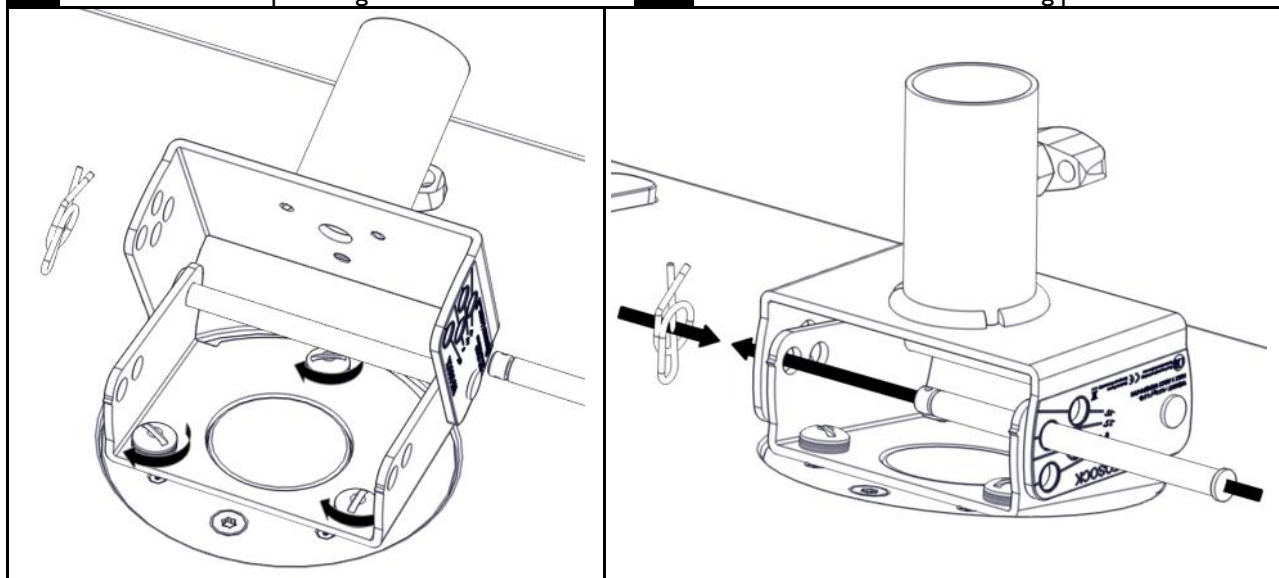

3. WIFOSOCK being secured with a quarter-turn

4. WIFOSOCK in position, the pin being reinstalled into the chosen angle hole

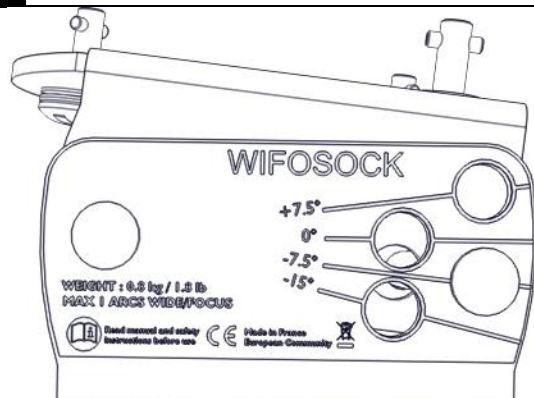

Selected angle on WIFOSOCK	Realized site angle	
	ARCS® WIDE	ARCS® FOCUS
-15,0°	0,0°	-7,5°
-7,5°	7,5°	0,0°
0,0°	15,0°	7,5°
7,5°	22,5°	15,0°

4. Possible angles with the WIFOSOCK.



## APPENDIX A PULLBACK IMPLEMENTATION

### A. Vertical Array



**Maximum configurations.**

2 or 4 ARCS® WIDE/FOCUS enclosures array for 1 WIFOBUMP frame.

6 or 8 ARCS® WIDE/FOCUS enclosures array for 2 WIFOBUMP frames.



Quick-link DIN 56926 B WLL 140 kg attached to the hole of the last two WIFORIG bars with a bridled hang.

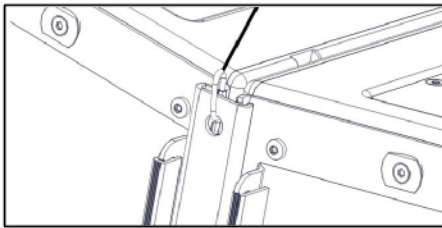

Shackle on hole 15 on the central bar of the WIFOBUMP frame.



Maximum angle between legs = 120°

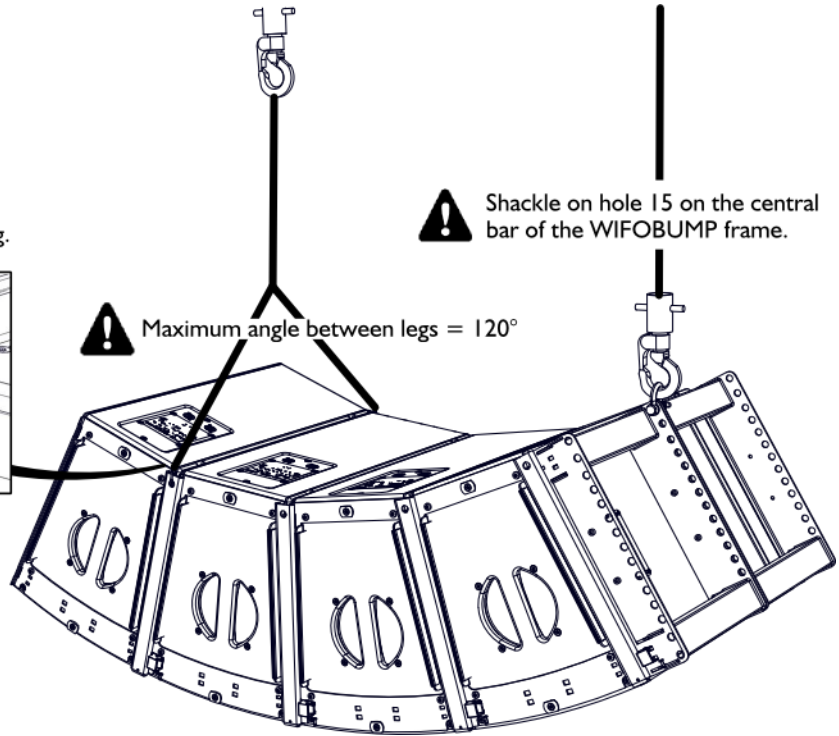

The WIFOBUMP is not delivered with WIFORIG bars. Borrow rigging bars from another ARCS WIFO enclosure.



Shackle on hole 15 of central bar of both WIFOBUMP frames.

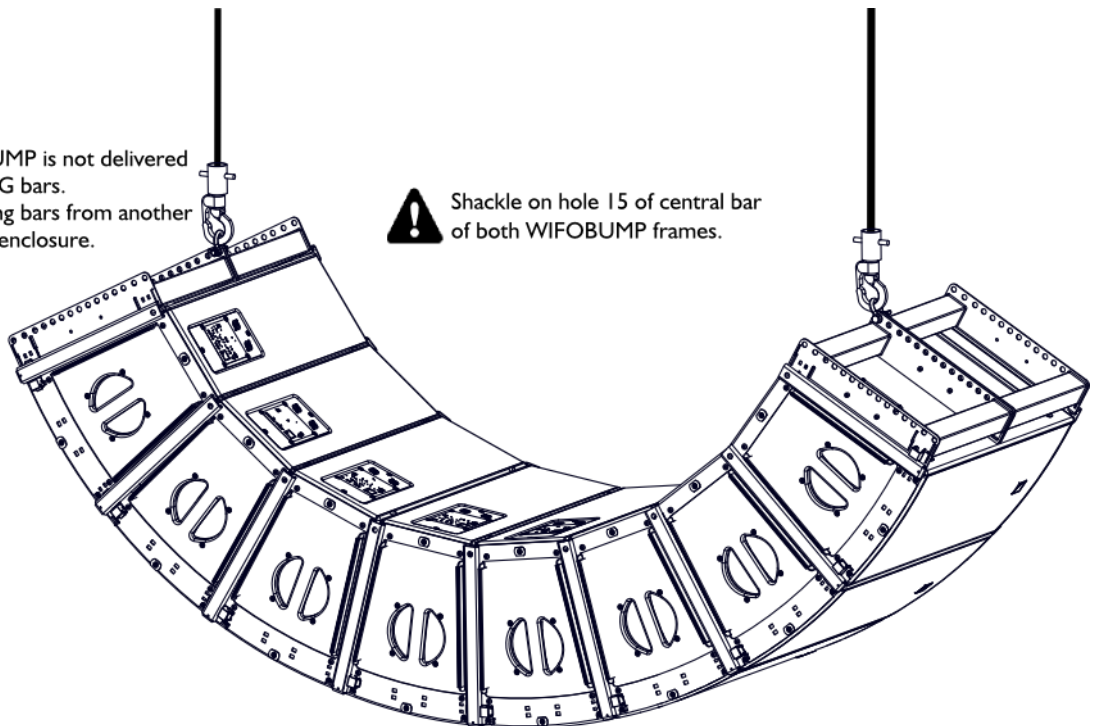

## B. Horizontal array



### Maximum configurations.

2 or 4 ARCS® WIDE/FOCUS enclosures array for 1 WIFOLIFT.

3 or 5 ARCS® WIDE/FOCUS enclosures array for 2 WIFOLIFT and 1 WIFOLIFTBAR.

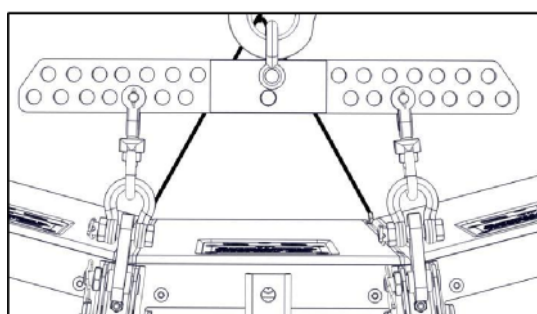
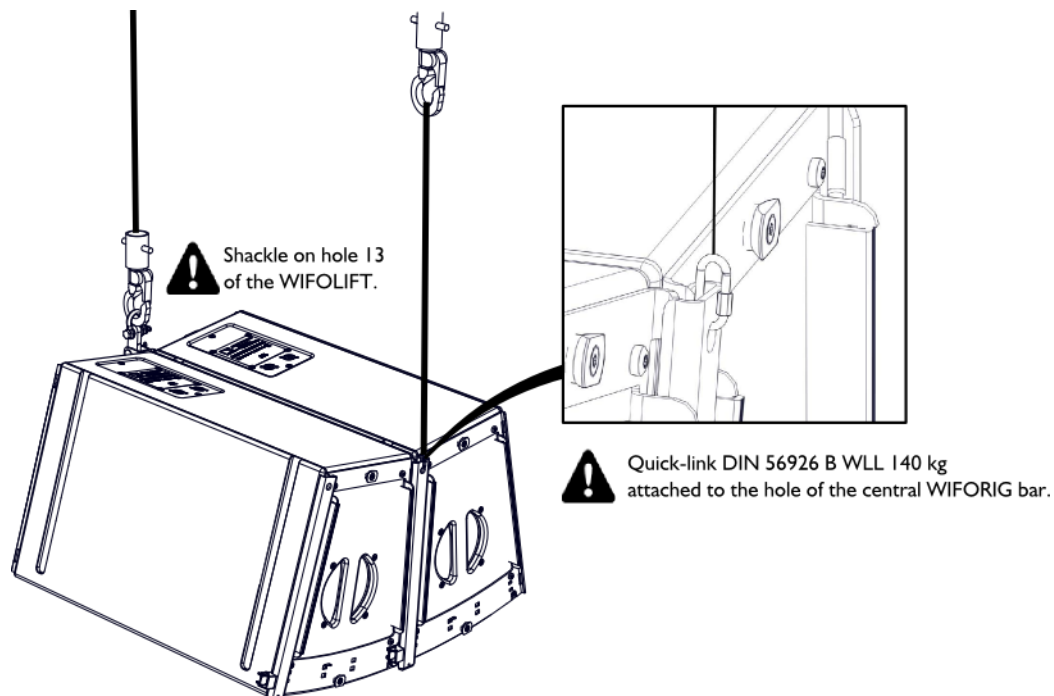

The WIFOLIFTBAR swivel shackles and WIFOLIFT rigging arms must form a straight line when the enclosure is in its final position. Choose the appropriate WIFOLIFTBAR hole, see **PROCEDURE B Attaching a WIFOLIFTBAR**.

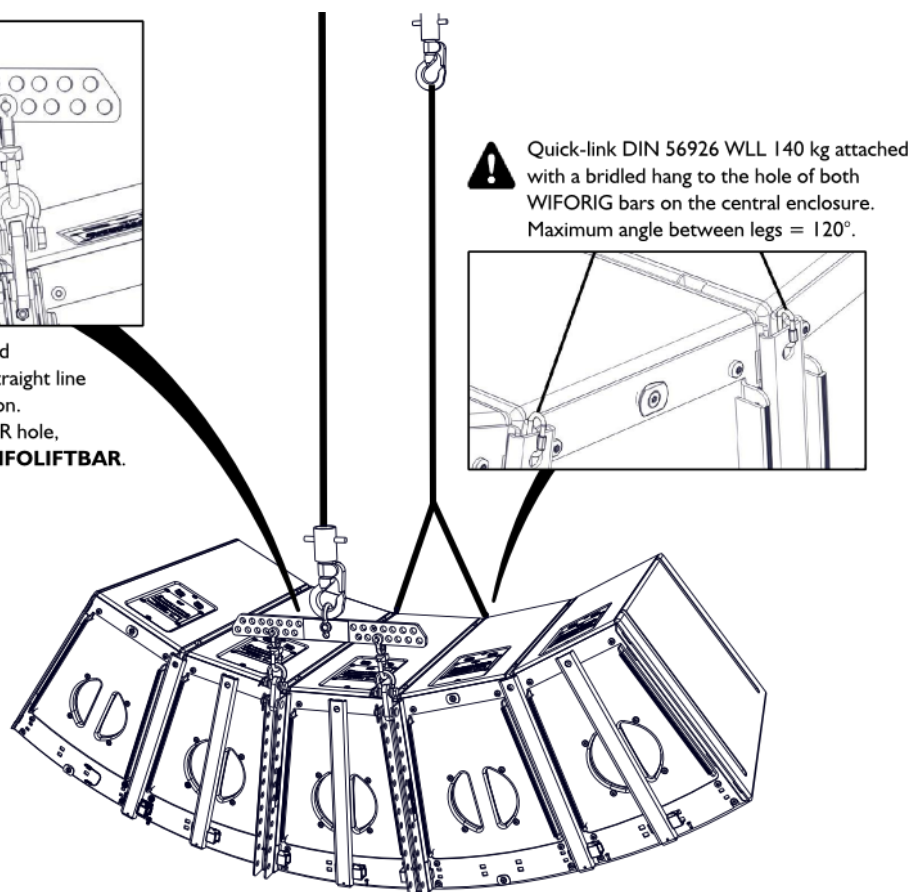

**APPENDIX B TILT ANGLE REFERENCE CHARTS**

Tilt angle reference chart WIFOLIFT

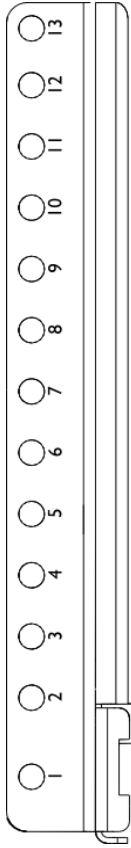

WIFOLIFT hole	2 ARCS® FOCUS	2 ARCS® WIDE	4 ARCS® FOCUS	4 ARCS® WIDE	6 ARCS® FOCUS	6 ARCS® WIDE	8 ARCS® FOCUS	8 ARCS® WIDE
1	26,4°	26,6°	30,7°	33,4°	37,3	33,1	27,0°	18,1°
2	21,3°	21,6°	26,1°	29,1°	33,7	29,5	22,8°	15,4°
3	17,2°	17,5°	22,3°	25,5°	30,6	26,5	19,3°	13,2°
4	12,9°	13,1°	18,2°	21,6°	27,3	23,4	15,7°	11,0°
5	8,4°	8,7°	14,0°	17,6°	23,8	20,0	12,0°	8,8°
6	3,8°	4,1°	9,6°	13,3°	20,1	16,6	8,2°	6,5°
7	-0,9°	-0,5°	5,1°	8,9°	16,2	13,0	4,2°	4,2°
8	-5,5°	-5,2°	0,5°	4,4°	12,2	9,3	0,3°	1,9°
9	-10,1°	-9,7°	-4,1°	-0,2°	8,1	5,5	-3,7°	-0,4°
10	-14,5°	-14,2°	-8,6°	-4,7°	3,8	1,7	-7,6°	-2,7°
11	-18,8°	-18,4°	-13,1°	-9,3°	-0,5	-2,2	-11,4°	-5,0°
12	-22,9°	-22,5°	-17,4°	-13,7°	-4,8	-6,0	-15,2°	-7,3°
13	-26,4°	-26,1°	-21,2°	-17,6°	-8,7	-9,5	-18,5°	-9,3°



**Tilt angle reference chart WIFOLIFTBAR**

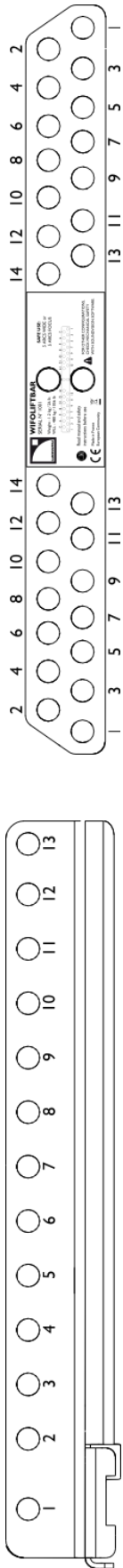

WIFOLIFT hole	3 ARCS® FOCUS		3 ARCS® WIDE		5 ARCS® FOCUS		5 ARCS® WIDE		6 ARCS® WIDE	
	WIFOLIFTBAR HOLE	Tilt angle	WIFOLIFTBAR HOLE	Tilt angle	WIFOLIFTBAR HOLE	Tilt angle	WIFOLIFTBAR HOLE	Tilt angle	WIFOLIFTBAR HOLE	Tilt angle
1	2	26,5°	2	26,0°	2	32,3°	1	34,7°		
2	3	21,6°	3	21,8°	3	28,0°	2	30,9°		
3	3	17,6°	4	17,9°	3	24,4°	3	27,5°		
4	4	13,4°	5	13,8°	4	20,4°	4	23,9°		
5	5	9,0°	6	9,5°	4	16,4°	5	20,2°		
6	5	4,8°	7	4,4°	5	12,1°	6	16,3°		
7	6	0,2°	8	1,1°	5	7,8°	7	12,4°		
8	6	-4,4°	9	-3,2°	6	3,3°	9	8,2°		
9	7	-8,9°	10	-7,4°	6	-1,3°	10	4,0°	2	5,1°
10	7	-13,1°	11	-11,7°	7	-5,7°	11	-0,1°	3	1,4°
11	8	-17,3°	12	-15,7°	7	-10,0°	12	-4,3°	4	-2,2°
12	8	-21,4°	13	-19,7°	8	-14,4°	13	-8,8°	5	-5,7°
13	9	-25,0°	14	-23,1°	8	-18,2°	14	-12,5°	6	-9,3°

█ = not applicable

**Tilt angle reference chart WIFOBUMP (homogeneous arrays)**

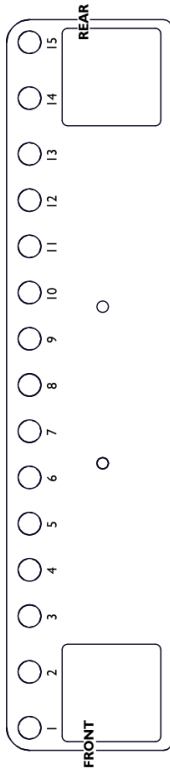

WIFOBUMP hole	1 ARCS® FOCUS	1 ARCS® WIDE	2 ARCS® FOCUS	2 ARCS® WIDE	4 ARCS® FOCUS	4 ARCS® WIDE	6 ARCS® FOCUS	6 ARCS® WIDE	8 ARCS® FOCUS	8 ARCS® WIDE
1	47,9°	51,4°	35,4°	43,0°	32,3°	48,1°	60,0°	60,0°	43,8°	71,8°
2	43,0°	46,6°	31,6°	39,3°	30,1°	46,0°	58,7°	58,7°	42,7°	71,1°
3	37,1°	40,7°	27,4°	35,2°	27,8°	43,8°	57,4°	57,4°	41,6°	70,3°
4	31,5°	34,9°	23,8°	31,4°	25,8°	41,8°	56,2°	56,2°	40,6°	69,6°
5	25,1°	28,2°	19,9°	27,2°	23,7°	39,7°	54,9°	54,9°	39,6°	68,8°
6	17,9°	20,5°	15,8°	22,8°	21,6°	37,5°	53,6°	53,6°	38,6°	68,0°
7	10,2°	11,9°	11,5°	18,0°	19,4°	35,1°	52,2°	52,2°	37,6°	67,2°
8	2,0°	2,8°	7,1°	12,9°	17,1°	32,5°	50,6°	50,6°	36,5°	66,2°
9	-6,2°	-6,5°	2,6°	7,7°	14,8°	29,8°	49,0°	49,0°	35,4°	65,2°
10	-14,2°	-15,4°	-1,9°	2,3°	12,4°	27,0°	47,2°	47,2°	34,3°	64,1°
11	-21,7°	-23,7°	-6,4°	-3,2°	10,0°	23,9°	45,3°	45,3°	33,1°	62,9°
12	-28,4°	-31,0°	-10,8°	-8,5°	7,6°	20,8°	43,3°	43,3°	32,0°	61,7°
13	-34,5°	-37,3°	-15,1°	-13,8°	5,1°	17,5°	41,1°	41,1°	30,7°	60,2°
14	-40,7°	-43,8°	-20,1°	-19,8°	2,1°	13,4°	38,3°	38,3°	29,2°	58,4°
15	-46,0°	-49,1°	-24,7°	-25,4°	-1,0°	9,1°	35,3°	35,3°	27,6°	56,3°

= not applicable with the CLAMP250

**Tilt angle reference chart WIFOBUMP (hybrid arrays)**

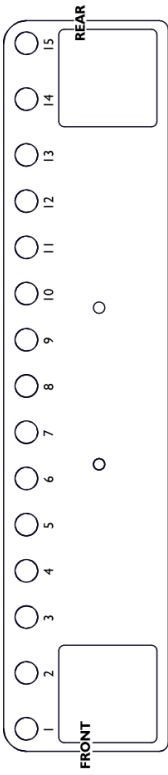

WIFOBUMP hole	2 SBI18m and 4 ARCS® FOCUS		2 SBI18m and 4 ARCS® WIDE		1 SBI18m and 2 ARCS® FOCUS		1 SBI18m and 2 ARCS® WIDE	
	Front position	Rear position	Front position	Rear position	Front position	Rear position	Front position	Rear position
1	16,8°	4,5°	20,7°	7,3°	24,1°	0,9°	26,6°	2,4°
2	15,4°	3,0°	19,1°	5,6°	21,5°	-2,1°	24,0°	-0,8°
3	14,0°	1,4°	17,6°	3,9°	18,9°	-5,0°	21,3°	-3,9°
4	12,8°	0,1°	16,3°	2,4°	16,7°	-7,5°	19,0°	-6,6°
5	11,5°	-1,1°	15,0°	1,0°	14,4°	-9,9°	16,6°	-9,1°
6	10,3°	-2,4°	13,6°	-0,4°	12,1°	-12,2°	14,2°	-11,7°
7	9,0°	-3,7°	12,3°	-1,8°	9,7°	-14,6°	11,7°	-14,2°
8	7,8°	-5,0°	10,9°	-3,3°	7,3°	-16,9°	9,1°	-16,6°
9	6,5°	-6,3°	9,5°	-4,7°	4,8°	-19,1°	6,5°	-19,0°
10	5,3°	-7,5°	8,1°	-6,1°	2,4°	-21,3°	3,9°	-21,3°
11	4,0°	-8,8°	6,7°	-7,5°	-0,1°	-23,4°	1,3°	-23,6°
12	2,7°	-10,0°	5,3°	-8,9°	-2,6°	-25,4°	-1,3°	-25,8°
13	1,4°	-11,3°	3,9°	-10,3°	-5,0°	-27,4°	-3,9°	-27,9°
14	-0,1°	-12,7°	2,1°	-12,0°	-8,0°	-29,7°	-7,1°	-30,3°
15	-1,7°	-14,2°	0,4°	-13,6°	-10,9°	-31,9°	-10,2°	-32,6°

## **APPENDIX C RECOMMENDED FLIGHT-CASE**

It is recommended to use a dedicated flight-case capable to fit 2 ARCS® WIDE/FOCUS enclosures in vertical position. Both the tray and cap should feature a foam insert cut according to the pattern illustrated below. This one allows for the different enclosure combinations: 2 ARCS® WIDE, 2 ARCS® FOCUS or 1 ARCS® WIDE / 1 ARCS® FOCUS.

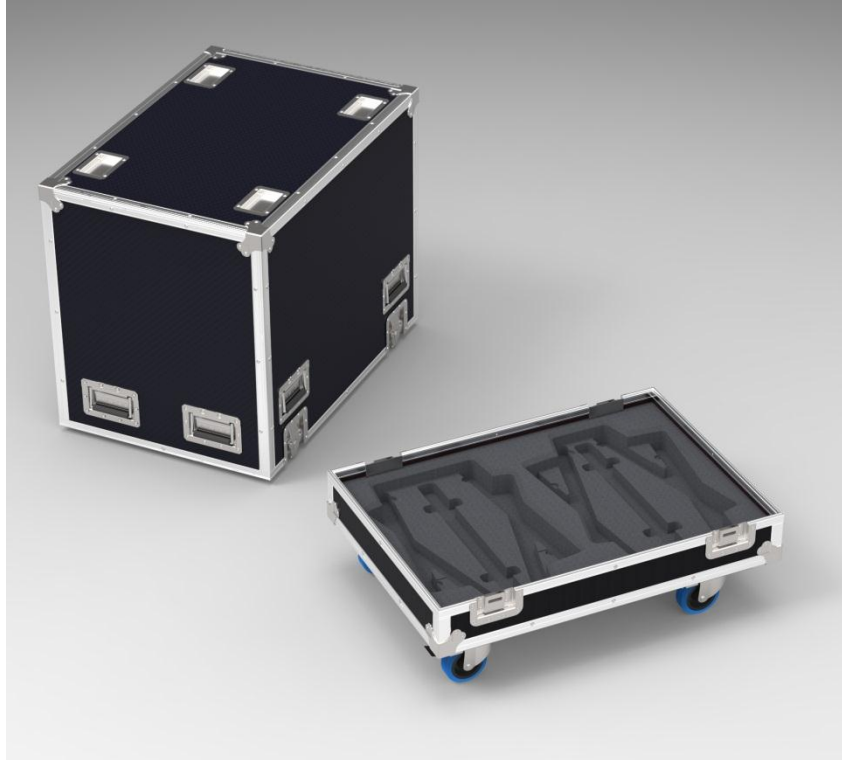

**Cap and tray of the flight-case**

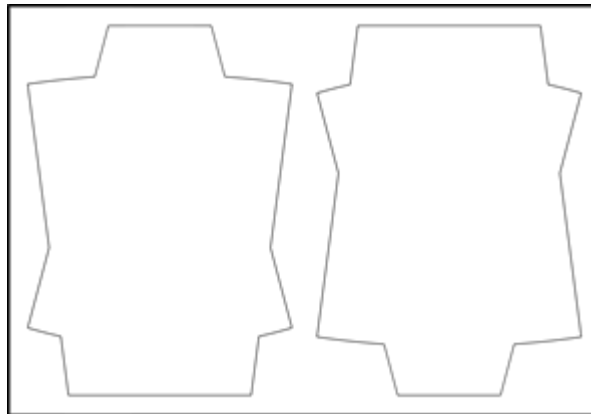

**Pattern of the foam insert for the cap and the tray**

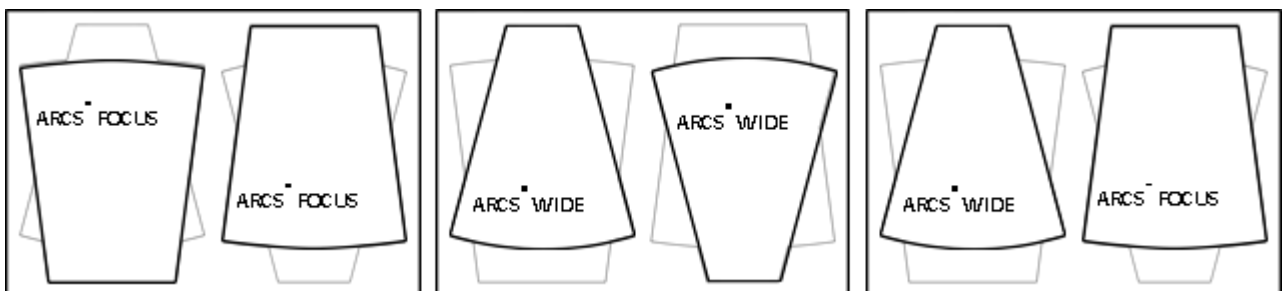

**Storage options**

## APPENDIX D SPECIFICATIONS

### ARCS® FOCUS

<b>Description</b>	2-way passive enclosure, amplified by LA4 or LA8
<b>Usable bandwidth (-10 dB)</b>	55 Hz - 20 kHz ([ARCS_WIFO] preset)
<b>Maximum SPL<sup>1</sup></b>	137 dB ([ARCS_WIFO] preset)
<b>Coverage angle (-6 dB)</b>	15° × 90°
<b>Transducers</b>	LF 1 × 3" diaphragm compression driver, DOSC® waveguide.
	HF 1 × 12" , weather-resistant, bass-reflex.
<b>Nominal impedance</b>	LF = 8 Ω
<b>RMS power handling</b>	450 W
<b>Connectors</b>	IN: 1 × 4-point SpeakOn® LINK: 1 × 4-point SpeakOn®
<b>Rigging components</b>	Rigging rails and WIFORIG rigging bars.

### Dimensions

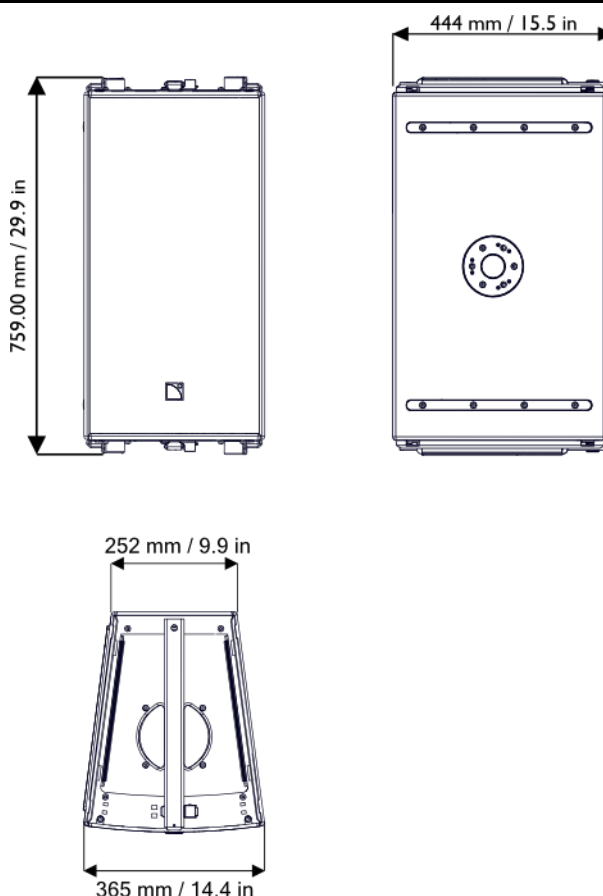

<b>Physical data</b>	<b>Weight (net):</b>	38 kg / 84 lb
	<b>Cabinet:</b>	Baltic birch plywood.
	<b>Finish:</b>	Grey brown RAL 8019® or Pure white RAL 9010®
	<b>Front:</b>	Steel grill with anti-corrosion coating, Airnet® fabric
	<b>Protection Rating:</b>	IP45
	<b>Rigging component:</b>	High strength steel with anti-corrosion coating

<sup>1</sup> Peak level at 1 m under free field conditions using 10 dB crest factor pink noise with specified preset.

**ARCS® WIDE**

<b>Description</b>	2-way passive enclosure, amplified by LA4 or LA8
<b>Usable bandwidth (-10 dB)</b>	55 Hz - 20 kHz ([ARCS_WIFO] preset)
<b>Maximum SPL<sup>1</sup></b>	135 dB ([ARCS_WIFO] preset)
<b>Coverage angle (-6 dB)</b>	30° × 90°
<b>Transducers</b>	LF 1 × 3" diaphragm compression driver, DOSC® waveguide. HF 1 × 12" , weather-resistant, bass-reflex.
<b>Nominal impedance</b>	8 Ω
<b>RMS power handling</b>	450 W
<b>Connectors</b>	IN: 1 × 4-point SpeakOn® LINK: 1 × 4-point SpeakOn®
<b>Rigging components</b>	Rigging rails and WIFORIG rigging bars.

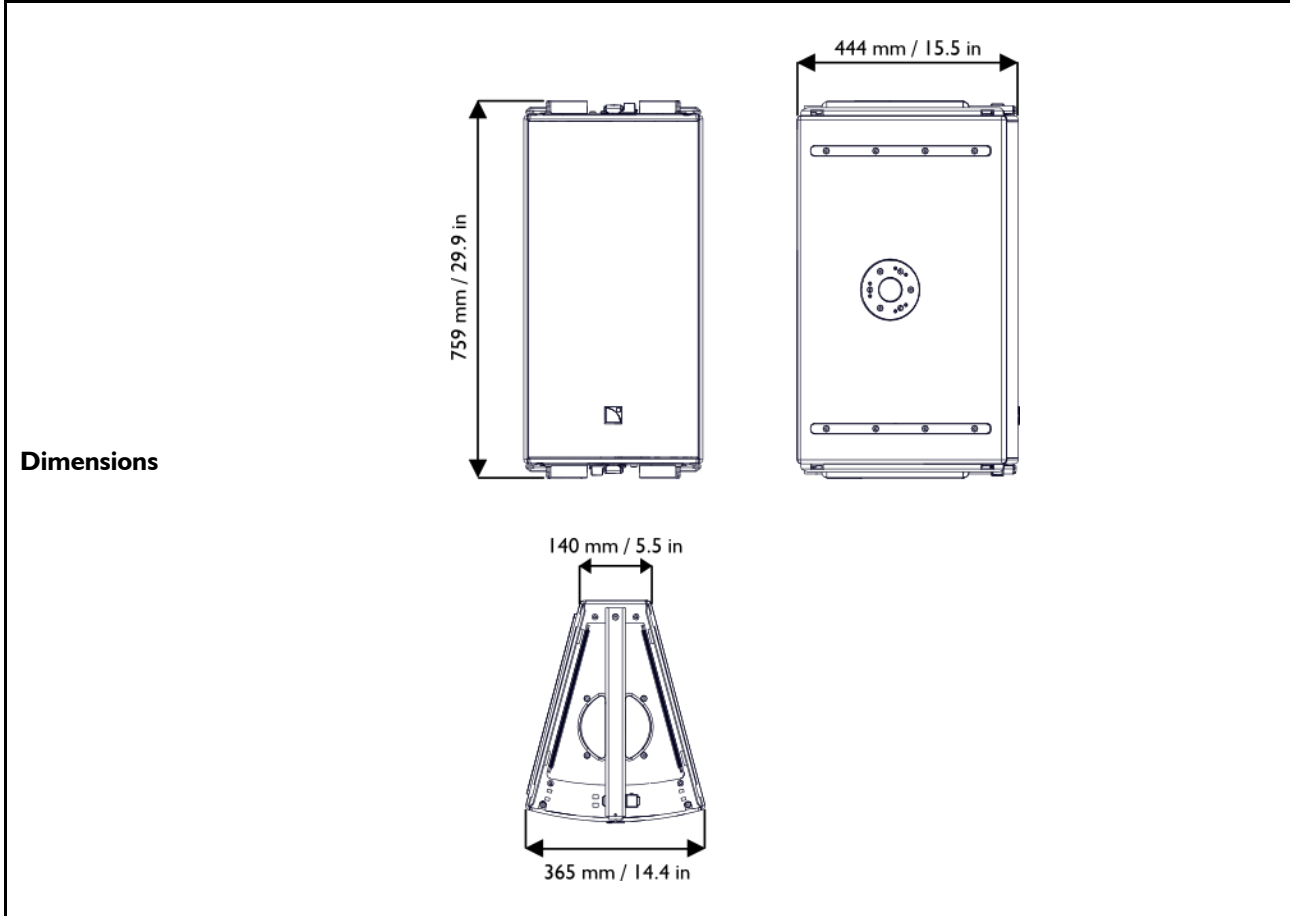

<b>Physical data</b>	<b>Weight (net):</b>	38 kg / 84 lb
	<b>Cabinet:</b>	Baltic birch plywood.
	<b>Finish:</b>	Grey brown RAL 8019® or Pure white RAL 9010®
	<b>Front:</b>	Steel grill with anti-corrosion coating, Airnet® fabric
	<b>Protection Rating:</b>	IP45
	<b>Rigging component:</b>	High strength steel with anti-corrosion coating

<sup>1</sup> Peak level at 1 m under free field conditions using 10 dB crest factor pink noise with specified preset.

## SBI8m

<b>Description</b>	Subwoofer enclosure, amplified by LA4 or LA8
<b>Low frequency limit (-10 dB)</b>	32 Hz ([SB18_100] preset)
<b>Maximum SPL<sup>1</sup></b>	136 dB ([SB18] preset)
<b>RMS power handling</b>	700 W
<b>Transducers</b>	1 × 18" weather resistant, dual bass-reflex
<b>Nominal impedance</b>	8 Ω
<b>Connectors</b>	IN: 1 × 4-point SpeakOn® LINK: 1 × 4-point SpeakOn®
<b>Rigging components</b>	Rigging rails and two SB18RIG rigging bars.

### Dimensions

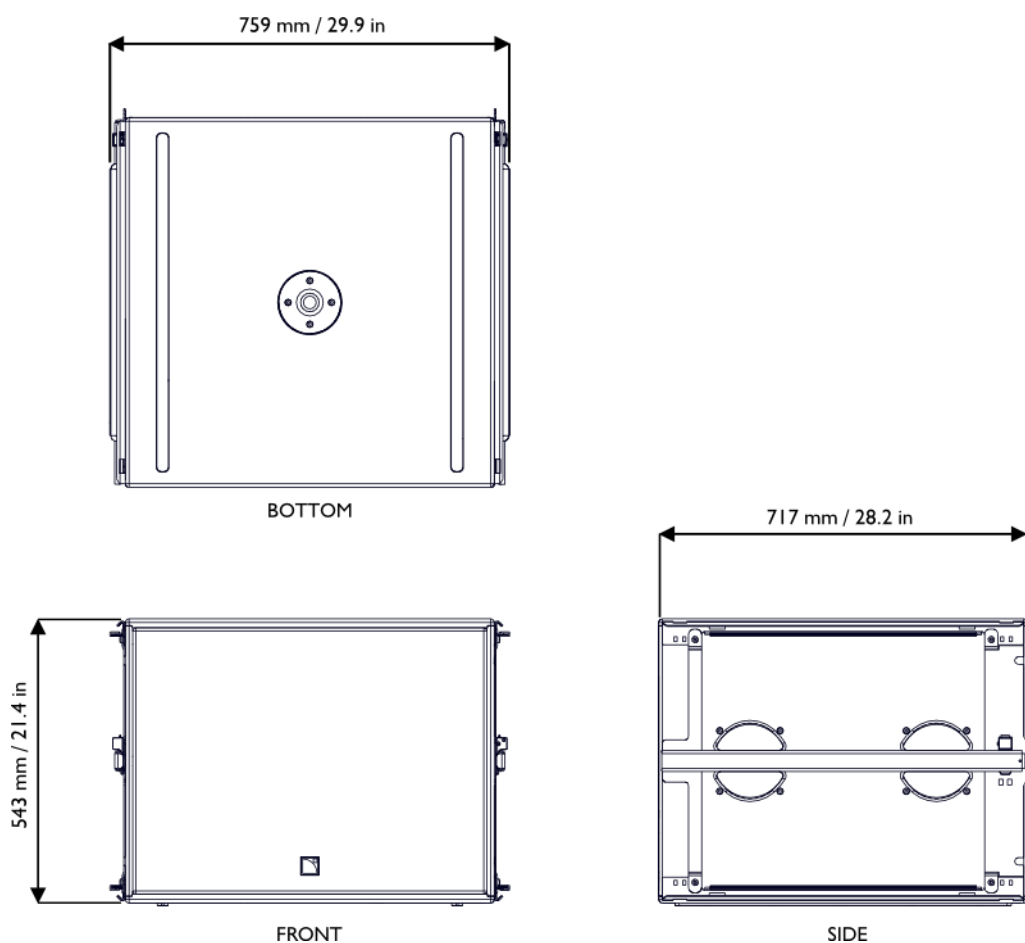

<b>Physical data</b>	<b>Weight (net):</b>	62 kg/137 lbs
	<b>Cabinet:</b>	Baltic birch plywood
	<b>Finish:</b>	Grey brown, RAL 8019® or Pure white, RAL 9010® RAL code on special order
	<b>Front:</b>	Steel grill with anti-corrosion coating Airnet® acoustically neutral fabric
	<b>Protection Rating:</b>	IP45
	<b>Rigging component:</b>	High strength steel

<sup>1</sup> Peak level at 1 m under half-space conditions using 10 dB crest factor pink noise with specified preset.

**CLAMP250**

<b>Description</b>	Rigging element		
<b>Dimensions</b>			
<b>Weight</b>	1,8 kg / 4 lb	<b>Material</b>	Steel with anti-corrosion coating

**WIFOBUMP**

<b>Description</b>	Rigging element for the ARCS® WIDE SYSTEM and the ARCS® FOCUS SYSTEM		
<b>Dimensions</b>			
<b>Weight</b>	10,5 kg / 23.1 lb	<b>Material</b>	Steel with anti-corrosion coating

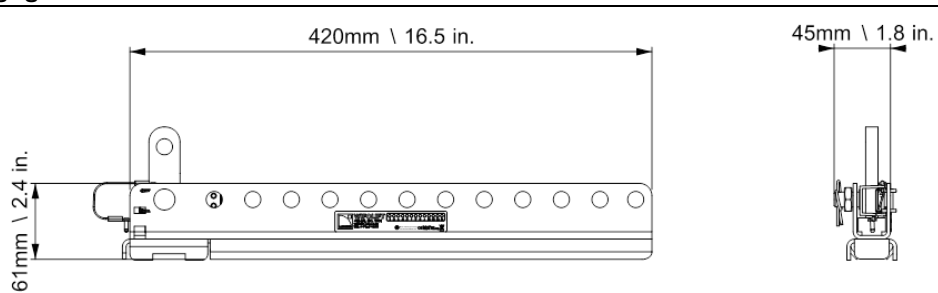

### WIFOLIFT

<b>Description</b>	Rigging element for the ARCS® WIDE SYSTEM and the ARCS® FOCUS SYSTEM		
<b>Dimensions</b>			
<b>Weight</b>	2 kg / 4.4 lb	<b>Material</b>	Steel with anti-corrosion coating

### WIFOLIFTBAR

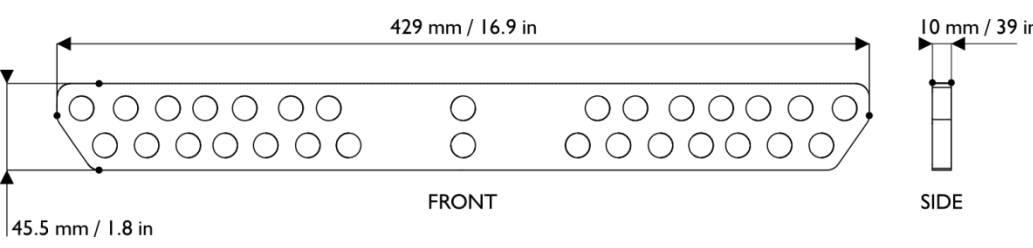
<b>Description</b>	Rigging element for the ARCS® WIDE and ARCS® FOCUS enclosure		
<b>Dimensions</b>			
<b>Weight</b>	1.6 kg	<b>Material</b>	High-grade steel with anti-corrosion coating

### WIFOSOCK

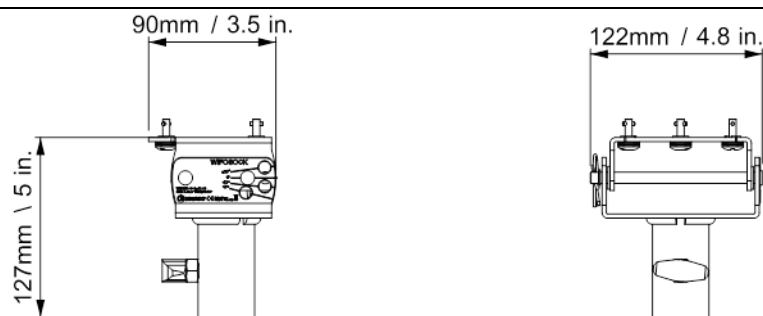
<b>Description</b>	Rigging element for the ARCS® WIDE SYSTEM and the ARCS® FOCUS SYSTEM		
<b>Dimensions</b>			
<b>Weight</b>	0,8 kg / 1.8 lb	<b>Material</b>	Steel with anti-corrosion coating



**Document reference: ARCSWIFO\_RM\_EN\_2.0**  
**Distribution date: April 9, 2013**

© 2013 L-ACOUSTICS®. All rights reserved.

No part of this publication may be reproduced or transmitted in any form  
or by any means without the express written consent of the publisher.